

Attrezzature per indirizzo Alberghiero

Sous Vide | Planetarie | Piastre Induzione | Salamandre | Fry Top Elettrici



Linea
EntryLine



Visita il nostro store



www.mydidactstore.it

another way to care

 **Didact**
my
STORE



Identità di Gruppo

“Lavoriamo con passione per lo sviluppo di soluzioni innovative.”

ABINTRAX è un'azienda impegnata nello sviluppo di prodotti e soluzioni professionali utilizzate nel campo della didattica e dell'assistenza clinica alla persona.

L'esperienza acquisita negli anni, insieme alla maturità e alla consapevolezza di dover affrontare i mercati con grande entusiasmo, hanno portato un nutrito gruppo di professionisti, derivanti da diverse esperienze in campo tecnologico, ad evolversi in una realtà nuova che trae la sua forza dalla spiccata spinta innovativa e dalla ricerca di soluzioni tecnologiche performanti.

Cuore dell'azienda è il reparto per la ricerca e lo sviluppo di nuovi prodotti hardware e software, integrate in soluzioni ad alto contenuto tecnologico.



Le nostre principali competenze specifiche sono:



SYSTEMS INTEGRATION

Creazione di infrastrutture e reti informatiche che consentono l'interazione e l'interconnessione tra diverse tecnologie

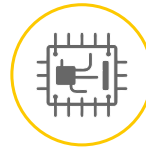

HARDWARE DESIGN

Progettazione, sviluppo e produzione di componenti hardware, circuiti integrati e apparecchiature elettroniche



SOFTWARE DESIGN

Progettazione e sviluppo industriale di applicativi e soluzioni software ad uso professionale

Organizzazione aziendale

Divisione R&S | Regulatory affairs | Ufficio Gare | Uffici commerciali | Uffici operativi di commessa | Support & Customer care | Laboratori e Magazzini.

Responsabili aziendali di area

Area 1 - Sig. Pietro: p.rosato@didact.abintrax.com

mobile 351 0419612 (anche  WhatsApp) Calabria, Puglia, Basilicata, Campania, Sicilia

Area 2 - Sig. Vito: v.cito@abintrax.com

mobile 345 0322557 (anche  WhatsApp) Lombardia, Veneto, Friuli, Toscana, Emilia Romagna, Umbria, Trentino Alto Adige, Valle D'Aosta

Area 3 - Sig.ra Rosalia: r.defelice@abintrax.com

mobile 344 0774237 (anche  WhatsApp) Lazio, Abruzzo, Marche, Sardegna, Molise, Liguria, Piemonte

La Nostra Storia

ABINTRAX, dal latino Ab Intra, nasce appunto "dall'interno" di realtà scafate con elevatissima esperienza, affermate e leader in mercati tecnologici. Fonde insieme competenze e professionalità di altissima specializzazione per offrire soluzioni in linea con le dinamiche e le esigenze del mercato ormai globalizzato. Cuore dell'azienda è il reparto per la ricerca e lo sviluppo di nuovi prodotti con esperienza in ambito di sviluppo software e di dispositivi hardware e soluzioni ad alto contenuto tecnologico.

Mission

«Lavoriamo con passione per lo sviluppo di soluzioni innovative capaci di consentire il superamento delle disparità economiche e sociali attraverso uno sviluppo tecnologico sostenibile. Siamo fortemente impegnati a mettere la nostra esperienza a servizio della comunità in modo efficace ed efficiente, migliorando le prestazioni e il valore fornito ai nostri stakeholder.»
Abintrax è alla continua ricerca di soluzioni e tecnologie innovative capaci di migliorare i propri prodotti, per offrire le migliori soluzioni per i propri partner.

Vision

Crediamo fermamente che il progresso, la tecnologia e l'innovazione devono essere al servizio dei cittadini e della comunità.
Lavoriamo per sviluppare strumenti tecnologici sostenibili in grado di colmare le differenze e ridurre le distanze al fine di poter contribuire alla creazione di servizi eccellenti per le persone e per migliorare la qualità della vita.
Abintrax continuerà a sostenere lo sviluppo di una comunità attiva che investe nelle persone, per le persone.

Ogni prodotto dispone di scheda tecnica e relative certificazioni.
Ogni ulteriore utile informazione può essere richiesta tramite posta elettronica all'indirizzo email commerciale@didact.abintrax.com

Tutti i prodotti sono disponibili per ordini sulla piattaforma MePA

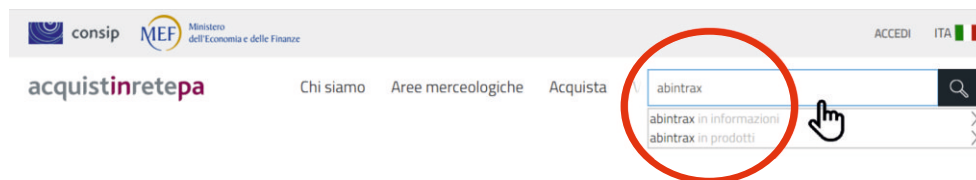



















Distributore esclusivo dei marchi



Alcuni tra i nostri principali partner



Icone

	IT	EN	FR	DE	ES	RU
	INFORMAZIONI	INFORMATION	INFORMATION	INFO	INFORMACIÓN	ИНФОРМАЦИЯ
	POTENZA	POWER	PUISSANCE	LEISTUNG	POTENCIA	МОЩНОСТЬ
	ALIMENTAZIONE TRIFASE	THREE-PHASE POWER SUPPLY	ALIMENTATION TRIPHASÉE	DREIPHASIGE STROMVERSORGUNG	ALIMENTACIÓN TRIFÁSICA	ТРЕХФАЗНЫЙ ИСТОЧНИК ПИТАНИЯ
	ALIMENTAZIONE MONOFASE	SINGLE-PHASE POWER SUPPLY	ALIMENTATION MONOPHASÉE	EINPHASIGE STROMVERSORGUNG	ALIMENTACIÓN MONOFÁSICA	ОДНОФАЗНЫЙ ИСТОЧНИК ПИТАНИЯ
	DIMENSIONI MACCHINA	MACHINE DIMENSIONS	DIMENSIONS DES MACHINES	MASCHINE NABMESSUNGEN	MEDIDAS MÁQUINA	РАЗМЕРЫ СТАНКА
	INFO SPEDIZIONI	DELIVERY INFO	INFORMATIONS SUR LA LIVRAISON	VERSANDINFO	INFORMACIÓN SOBRE ENVÍO	ИНФОРМАЦИЯ ИНФОРМАЦИЯ ШИППИНГА
	PESO NETTO	NET WEIGHT	POIDS NET	NETTOGEWICHT	PESO NETO	ВЕС НЕТТО
	PESO LORDO	GROSS WEIGHT	POIDS BRUT	BRUTTOGEWICHT	PESO BRUTO	ВЕС БРУТТО
	DIMENSIONI DI IMBALLO	PACKAGING DIMENSIONS	DIMENSIONS DES EMBALLAGES	VERPACKUNGSMASSE	MEDIDAS DEL EMBALAJE	РАЗМЕРЫ УПАКОВКИ
	VOLUME DI IMBALLO	PACKING VOLUME	VOLUME D'EMBALLAGE	VERPACKUNGSUMFANG	VOLUMEN DEL EMBALAJE	ОБЪЕМ УПАКОВКИ
	PREZZO	PRICE	PRIX	PREIS	PRECIO	ПРИСЕ
	CE	CE	CE	CE	CE	CE
	BARRA SALDANTE	SEALING BAR	BARRE DE SOUDURE	SCHWEISSSTAB	BARRA TERMOSELLADO	СВАРОЧНАЯ ПЛАНКА
	POMPA VUOTO	VACUUM PUMP	POMPE A VIDER	VAKUUM PUMPE	BOMBA VACÍO	ВАКУУМНЫЙ НАСОС
	VUOTO MAX OTTENIBILE/ MAX ACHIEVABLE VACUUM	MAX. VAKUUM ACHIEVABLE	VIDE MAX POSSIBLE	MAX ERREICHBARES VAKUUM	MÁX. VACÍO POSIBLE	МАКСИМАЛЬНО ВОЗМОЖНАЯ ВАКУУМНЫЙ
	DIMENSIONI DEL PIANO DI LAVORO	DIMENSIONS OF THE WORKTOP	DIMENSIONS DU PLAN DE TRAVAIL	ABMESSUNGEN DER ARBEITSPLATTE	MEDIDAS DEL PLAN DE TRABAJO	РАЗМЕРЫ СТОЛЕШНИЦЫ
	POTENZA RISCALDAMENTO	HEATING POWER	PUISSANCE DE CHAUFFAGE	HEIZLEISTUNG	POTENCIA CALORÍFICA	МОЩНОСТЬ НАГРЕВА
	TEMPERATURA DI LAVORO	WORKING TEMPERATURE	TEMPÉRATURE DE FONCTIONNEMENT	BETRIEBSTEMPERATUR	TEMPERATURA DE TRABAJO	РАБОЧАЯ ТЕМПЕРАТУРА



Icone

	IT	EN	FR	DE	ES	RU
	VELOCITÀ	SPEED	VITESSE	GESCHWINDIGKEIT	VELOCIDAD	СКОРОСТЬ
	CAPACITÀ DEL BICCHIERE	GLASS CAPACITY	CAPACITÉ DU VERRE	BECHERKAPAZITÄT	CAPACIDAD VASO	ЁМКОСТЬ СТЕКЛА
	TIMER	TIMER	MINUTERIE	SCHALTUHR	TEMPORIZADOR	ТАЙМЕР
	DIMENSIONI DEL PIANO DI COTTURA	DIMENSIONS OF THE COOKING SURFACE	DIMENSIONS DE LA TABLE DE CUISSON	ABMESSUNGEN DER KOCHPLATTE	MEDIDAS DE LA PLACA DE COCCIÓN	РАЗМЕРЫ ВАРОЧНОЙ ПАНЕЛИ
	PRODUZIONE ORARIA	HOURLY PRODUCTION	PRODUCTION HORAIRE	STUNDENPRODUKTION	PRODUCCIÓN HORARIA	ПОЧАСОВОЕ ПРОИЗВОДСТВО
	CAPACITÀ DEL CONTENITORE	CONTAINER CAPACITY	CAPACITÉ DU CONTENANT	BEHÄLTERKAPAZITÄT	CAPACIDAD RECIPIENTE	ВМЕСТИМОСТЬ КОНТЕЙНЕРА
	CAPACITÀ OLIO	OIL CAPACITY	CAPACITÉ D'HUILE	ÖLKAPAZITÄT	CAPACIDAD ACEITE	МАСЛО КАПАБИЛЬТИЯ
	CAPACITÀ DEL CESTO DI COTTURA	CAPACITY OF THE COOKING BASKET	CAPACITÉ DE LA CUVE DE CUISSON	KAPAZITÄT DES KOCHKORBES	CAPACIDAD CESTA PARA COCCIÓN	ГЛАВНАЯ ИЛИ ВЫДЕЛЕННАЯ ПОВЕРХНОСТЬ ПЛИТЫ
	DIMENSIONE DELLA LAMA	BLADE SIZE	TAILLE DE LA LAME	KLINGENGRÖSSE	MEDIDA DE LA CUCHILLA	НОЖА
	TAGLIO UTILE	USEFUL CUT	COUPE UTILE	NÜTZLICHER SCHNITT	ÚTIL DE CORTE	ПОЛЕЗНАЯ ДЛИНА РЕЗКИ
	LAME	BLADES	LAMES	KLINGEN	CUCHILLAS	НОЖИ
	CAVALLETTO	STAND	SUPPORT	GESTELL	CABALLETE	МОЛЬБЕРТ
	CAPACITÀ / DIMENSIONI DELLA CAMERA DI COTTURA	CAPACITY / DIMENSIONS OF THE BAKING CHAMBER	CAPACITÉ / DIMENSIONS DE LA CHAMBRE DE CUISSON	BACKKAMMER KAPAZITÄT / ABMESSUNGEN	CAPACIDAD / DIMENSIONES DE LA CAMARA DE COCCIÓN	КАПАБИЛЬТИЯ / ВРЕМЕНИИ КАМЕРА ВЫПЕЧКИ
	DIMENSIONE RULLI	ROLLER DIMENSIONS	LONGUEUR DES ROULEAUX	ROLLENLÄNGE	LARGO RODILLOS ДЛИНА ВАЛКОВ	РАЗМЕР РОЛИКА



INDICE

IT	EN	FR	DE	ES	RU	
COTTURA SOUS-VIDE	SOUS-VIDE COOKING	CUISSON SOUS-VIDE	VAKUUM GAREN	COCCIÓN SOUS-VIDE	ВАКУУМНАЯ ВАРКА	8
MACCHINE SOTTOVUOTO A CAMPANA	CHAMBER VACUUM PACKERS	MACHINES SOUS VIDE À CLOCHE	KAMMER VAKUUMVERPACKER	ENVASADORAS AL VACÍO	КОЛПАКОВЫЕ ВАКУУМНЫЕ УПАКОВОЧНЫЕ МАШИНЫ	10
MACCHINE SOTTOVUOTO A BARRA SALDANTE	BAR VACUUM PACKERS	MACHINES SOUS VIDE À BARRE	VAKUUMVERPACKER MIT SCHWEISSLEISTE	ENVASADORAS AL VACÍO CON BARRA	ВАКУУМНЫЕ УПАКОВОЧНЫЕ МАШИНЫ СО СВАРОЧНОЙ ПЛАНКОЙ	12
FRULLATORI CON FUNZIONE COTTURA	MIXER WITH COOKING FUNCTION	MIXEUR AVEC FONCTION CUISSON	MIXER MIT KOCHFUNKTION	LICUADORA CON FUNCIÓN DE COCCIÓN	МЕШАЛКА С ФУНКЦИЕЙ ПРИГОТОВЛЕНИЯ ПИЩИ	16
FRULLATORI CON INSONORIZZATORE	MIXER WITH SOUND-PROOFER	MÉLANGEURS AVEC INSONORISATION	MIXER MIT SCHALLSCHUTZ	LICUADORA CON INSONORIZADOR	СМЕСИТЕЛИ СО ЗВУКОИЗОЛЯЦИЕЙ	18
ESTRATTORE DI SUCCHI	SLOW JUICER	EXTRACTEUR DE JUS	SAFTPRESSE	EXTRACTOR DE ZUMO	СЛОВ ДЖУЙСЕР	20
CENTRIFUGA	CENTRIFUGES	CENTRIFUGEUSES	ZENTRIFUGEN	LICUADORA CENTRÍFUGA	ЦЕНТРИФУГИ	22
FRULLATORI FRAPPÈ	MILKSHAKER	BLENDERS À FRAPPÉS	MILKSHAKERS	LICUADORAS FRAPPÉ	БЛЕНДЕРЫ ДЛЯ ПРИГОТОВЛЕНИЯ ФРАППЕ	24
FRULLATORI	MIXERS	BLENDERS	MIXERS	LICUADORA	БЛЕНДЕРЫ	26
SPREMIAGRUMI	CITRUS JUICER	PRESSE-AGRUMES	ZITRUSPRESSE	EXPRIMIDORES	СОКОВЫЖИМАЛКИ ДЛЯ ЦИТРУСОВЫХ	30
WAFFLE MACHINE	WAFFLE MACHINE	APPAREIL À GAUFRES	WAFFELMASCHINEN	GOFRERA	МАШИНА ДЛЯ ВЫПЕКАНИЯ ВАФЕЛЬ	34
TOSTAPANE CONTINUO	TOASTER	GRILLE-PAIN CONTINU	TOASTER IM DAUERZYKLUS	TOSTADORA DE PAN CONTINUA	ТОСТЕР НЕПРЕРЫВНОГО ДЕЙСТВИЯ ДЛЯ ПРИГОТОВЛЕНИЯ ГРЕНОК	36
PIASTRE DI COTTURA IN GHISA	CAST IRON COOKING GRILLS	PLAQUES DE CUISSON EN FONTE	KOCHPLATTEN AUS GUSSEISEN	PLACA DE COCINA DE FUNDICIÓN	ЧУГУННЫЕ ВАРОЧНЫЕ ПАНЕЛИ	38
PIASTRE AD INDUZIONE	INDUCTION PLATES	PLAQUES A INDUCTION	INDUKTIONSPLETTEN	PLACAS DE INDUCCIÓN	ИНДУКЦИОННЫЕ ПЛИТЫ	40
PIASTRA A INDUZIONE CON WOK	WOK INDUCTION PLATE	PLAQUE À INDUCTION AVEC WOK	INDUKTIONSPLETTE MIT WOK	PLACA DE INDUCCIÓN CON WOK	ИНДУКЦИОННЫЕ ПЛИТЫ С WOK	42
IMPASTATRICE PLANETARIA	PLANETARY MIXER	MÉLANGEUR PLANÉTAIRE	PLANETENMISCHER	AMASADORA PLANETARIA	ПЛАНЕТАРНЫЙ ТЕСТОМЕС	44
PLANETARIE 3 VELOCITÀ	3-SPEED PLANETARY MIXER	MÉLANGEUR PLANÉTAIRE À 3 VITESSES	3-GANG PLANETENMISCHER	AMASADORA PLANETARIA 3 VELOCIDADES	3-СКОРОСТНОЙ ПЛАНЕТАРНЫЙ ТЕСТОМЕС	46
IMPASTATRICE PLANETARIA KITCHENAID	PLANETARY MIXER	MÉLANGEUR PLANÉTAIRE	PLANETENMISCHER	AMASADORA PLANETARIA	ПЛАНЕТАРНЫЙ ТЕСТОМЕС	50
FORNI A CONVEZIONE	CONVECTION OVENS	FOURS À CONVECTION	KONVEKTIONSOFEN	HORNOS DE CONVECCIÓN	КОНВЕКЦИОННЫЕ ПЕЧИ	54
FORNI MICROONDE	MICROWAVES OVENS	FOURS À MICRO-ONDES	SAMSUNG MIKROWELLEN	HORNOS MICROONDAS PROFESIONALES	ПРОФЕССИОНАЛЬНЫЕ МИКРОВОЛНОВЫЕ ПЕЧИ	56
FORNI A MICROONDE SAMSUNG	MICROWAVES OVENS	FOURS À MICRO-ONDES	MIKROWELLEN	HORNOS MICROONDAS	МИКРОВОЛНОВЫЕ ПЕЧИ	62
FORNI A MICROONDE PANASONIC	MICROWAVES OVENS	FOURS À MICRO-ONDES	MIKROWELLEN	HORNOS MICROONDAS	МИКРОВОЛНОВЫЕ ПЕЧИ	66
FRIGGITRICI	FRYERS	FRITTEUSES	FRITEUSEN	FREIDORAS	ФРИТЮРНИЦЫ	68
CUOCI RISO	RICE COOKER	CUISINIÈRE À RIZ	REISKOCHER	COCEDORES DE ARROZ	РИСОВАРКА	72
CUOCI HOT DOG	HOT DOG	HOT DOG	HOT DOG	PERRITO CALIENTE	АППАРАТ ДЛЯ ПРИГОТОВЛЕНИЯ ХОТ-ДОГОВ	74
AFFETTATRICI A GRAVITÀ	GRAVITY SLICERS	TRANCHEUSE À GRAVITÉ	SCHRÄGE AUFSCHNITTMASCHINEN	CORTADORAS POR GRAVEDAD	ГРАВИТАЦИОННЫЕ СЛАЙСЕРЫ	78
TAGLIA POMODORI MANUALI	MANUAL TOMATOES CUTTER	COUPE-TOMATES MANUELS	MANUELLER TOMATENSCHNEIDER	CORTADORA MANUAL DE TOMATES	РУЧНАЯ РЕЗКА ПОМИДОРОВ	80
INSACCATRICI MANUALI ORIZZONTALI	HORIZONTALSAUSAGE STUFFER	POISSOIRS A' SAUCISSE MANUELS	MANUELLE HORIZONTALE FÜLLMASCHINEN	EMBUTIDORAS MANUALES HORIZONTALES	РУЧНЫЕ ГОРИЗОНТАЛЬНЫЕ НАПОЛНИТЕЛЬНЫЕ МАШИНЫ	82
PRESSAMBURGER MANUALI	MANUAL HAMBURGER PRESS	PRESSE-HAMBURGER MANUELS	MANUELLE HAMBURGER-PRESSE	PRESA DE HAMBURGUESAS MANUAL	ПРЕСС ДЛЯ ГАМБУРГЕРОВ	84
BOLLITORE ELETTRICO	ELECTRIC KETTLE	BOUILLIÈRE ÉLECTRIQUE	WASSERKOCHER	HERVIDOR ELÉCTRICO	ЭЛЕКТРИЧЕСКИЙ ЧАЙНИК	86
COLTELLO ELETTRICO	ELECTRIC KNIFE	ELEKTRISCHES MESSER	COUTEAU ÉLECTRIQU	CUCHILLO ELÉCTRICO	ЭЛЕКТРИЧЕСКИЙ НОЖ	88
CATALOGO NOVITA'	NEW CATALOG	CATALOGUE DE NOUVELLES	NEWS-KATALOG	CATALOGO DE NOTICIAS	КАТАЛОГ НОВОСТЕЙ	90













ABX-FZ03A



Cottura sous-vide



- IT** Macchina per la cottura sottovuoto a bassa temperatura (sous-vide). Struttura in acciaio inox AISI 304 - capacità di scaldare fino a 30 L di acqua - sensore di temperatura - precisione di lavorazione +/- 0,5°C.
- EN** Low temperature vacuum cooking machine (sous-vide). Casing in stainless steel AISI 304 - water heating capacity of up to 30 L - temperature probe - working accuracy +/- 0,5°C.
- FR** Machine de cuisson sous vide à basse température (sous-vide). Corps en acier Inox AISI 304 - capacité de chauffage de l'eau jusqu'à 30 L - sonde de température - précision d'usinage +/- 0,5°C.
- DE** Niedertemperaturgargerät für das Vakuumkochen (sous-vide). Gehäuse aus Edelstahl AISI 304 - Wasserheizleistung bis zu 30 L - Temperaturfühler - Bearbeitungsgenauigkeit +/- 0,5°C.
- ES** Máquina de cocción al vacío de baja temperatura (sous-vide). Cuerpo en acero inoxidable AISI 304 - capacidad de calentamiento de agua de hasta 30 L - sensor de temperatura - precisión de tratamiento +/- 0,5°C.
- RU** Низкотемпературная варочная панель для приготовления в вакууме (су-вид). Корпус из нержавеющей стали AISI 304 - мощность водяного отопления до 30 л - Датчик температуры - Точность обработки +/- 0,5°C.

	ABX-FZ03A
	1,5 kW
 1 Ph	220-240V/1N/50-60Hz
	30 L
	140 x 110 x 332(h) mm
	
 NET Kg	2,5 Kg
 GROSS Kg	3 Kg
 mm	220 x 190 x 410(h) mm
 m ³	0,017 m ³
	
	450 €

ABX-SCC250

ABX-SCC300

ABX-SCC400

ABX-SCC500



ABX-SCC300

**Macchine sottovuoto
a campana**



IT Macchina per prolungare i tempi di conservazione degli alimenti mantenendone intatte le caratteristiche organolettiche e impedendo la proliferazione batterica. Struttura e vasca stampata in acciaio inox - barra saldante estraibile - coperchio in plexiglass trasparente - pompa a bagno d'olio - pannello comandi digitale con 6 programmi memorizzabili - possibile predisposizione per l'utilizzo di gas inerti (escluso mod. SCC250). Accessori: sacchetti lisci normali e per cottura in vari formati.













EN A machine to prolong food storage duration ensuring the integrity of the organoleptic characteristics and preventing bacterial growth. Stainless steel case and bowl - removable sealing bar - clear plexiglass lid - oil bath pump - digital control panel with 6 storable programs - prearrangement for the use of inert gases (excluding mod. SCC250). Accessories: normal smooth bags and cooking bags in various sizes.

FR Machine pour prolonger la durée de conservation des aliments, en conservant intactes leurs caractéristiques organoleptiques et en empêchant la prolifération des bactéries. Corps et cuve moulé en acier Inox - barre de soudure amovible - couvercle en plexiglas transparent - pompe à bain d'huile - panneau de commande numérique avec 6 programmes mémorisables - éventuelle prédisposition pour l'utilisation des gaz inertes (sauf le modèle SCC250). Accessoires: boîtes lisses normaux et sacs de cuisson de différentes tailles.

DE Maschine zur Verlängerung der Aufbewahrungsdauer von Lebensmitteln, um die Integrität der organoleptischen Eigenschaften zu gewährleisten und das Bakterienwachstum zu verhindern. Gehäuse und Schüssel aus Edelstahl - abnehmbare Schweißleiste - klarer Plexiglasdeckel - Ölbadpumpe - digitales Bedienfeld mit 6 speicherbaren Programmen - Inertgasen-Einsatzbereit (Außer Mod. SCC250). Zubehör: übliche Glattbeutel und Kochbeutel in verschiedenen Größen.

ES Máquina para prolongar el tiempo de conservación de los alimentos manteniendo sus características organolépticas. A través del uso de bolsas o contenedores especiales crea un nivel de vacío tal que impida la proliferación de bacterias. Estructura y cuba impresa de acero inoxidable - barra de termosellado extraíble - tapa en plexiglás transparente - bomba en aceite - panel de control digital con 6 programas memorizables - posible predisposición para el uso de gases inerte (mod. SCC250 excluido). Accesorios: bolsas lisas normales y para la cocción, de diferentes tamaños.

RU Машина для продления срока хранения продуктов. обеспечение целостности органолептических свойств и предотвращение роста бактерий. Корпус и чаша из нержавеющей стали - съемная уплотнительная планка - прозрачная плексигласовая крышка - масляные насосы - цифровая панель управления с 6 сохраняемыми программами - предварительное согласование для использования инертных газов (кроме модели SCC250). Аксессуары: обычные гладкие пакеты и варочные пакеты различных размеров.

	ABX-SCC250	ABX-SCC300	ABX-SCC400	ABX-SCC500
	0,35 kW (0,46 HP)	0,45 kW (0,6 HP)	0,75 kW (1 HP)	
	230V/1N/50Hz			
BARRA SALDANTE/ HOT-WELD SEALER	250 mm	300 mm	400 mm	500 mm
POMPA VUOTO/ VACUUM PUMP	4 m³/h	8 m³/h	20 m³/h	
VUOTO MAX OTTENIBILE/ MAX ACHIEVABLE VACUUM	98%			
	260 x 300 x 110(h) mm	310 x 350 x 190(h) mm	410 x 450 x 220(h) mm	520 x 520 x 220(h) mm
	320 x 500 x 270(h) mm	460 x 410 x 430(h) mm	560 x 510 x 460(h) mm	610 x 630 x 500(h) mm
				
	26 Kg	34 Kg	50 Kg	64 Kg
	32 Kg	40 Kg	58 Kg	74Kg
	550 x 470 x 620(h) mm	600 x 800 x 640(h) mm	600 x 800 x 680(h) mm	700 x 700 x 670(h) mm
	0,161 m³	0,307 m³	0,326 m³	0,329 m³
				
	2.135 €	2.520 €	2.830 €	3.898 €
	Special Voltages - Разное питающее напряжение + 65 €			

*Utilizzare solo buste per sottovuoto lisce.
Use only smooth vakuuum bags.
N'utilisez que des sacs sous vide lisses.
Nur glatte Vakuumbbeutel benutzen.
Utilizar exclusivamente bolsas para envasado al vacío lisas.
Использовать только гладкие пакеты для вакуума.

OPTIONAL



ABX-SBS300P
ABX-SBP350
ABX-SBP400



ABX-SBS300P



ABX-SBP350

ITALIAN
PRODUCT



ABX-SBP400

ITALIAN
PRODUCT

**Macchine sottovuoto
a barra saldante**



IT Macchina per prolungare i tempi di conservazione degli alimenti mantenendone intatte le caratteristiche organolettiche. Tramite l'utilizzo di apposite buste goffrate o contenitori si crea un livello di vuoto tale da impedire la proliferazione batterica. Carcassa in acciaio inox (in plastica ABS per il modello SBS300P) - pompa a secco - pannello comandi digitale con ciclo di lavoro automatico e/o manuale - saldatura da 5 mm.
Accessori: sacchetti goffrati in vari formati - rotoli goffrati per ottenere sacchetti della lunghezza desiderata.

EN A machine to prolong food storage duration ensuring the integrity of the organoleptic characteristics. The use of special embossed envelopes or containers creates a vacuum level that prevents the proliferation of bacteria. Stainless steel casing (ABS plastic for SBS300P model) - dry pump - digital control panel with automatic and/or manual working cycle - 5 mm sealing.
Accessories: embossed bags in various sizes - embossed rolls to obtain bags of the desired length.

FR Machine pour prolonger les temps de conservation des aliments tout en conservant intactes les caractéristiques organoleptiques. Grâce à l'utilisation de boîtes gaufrées ou de récipients spéciaux, on obtient un niveau de vide qui empêche la prolifération bactérienne. Corps en acier Inox (en plastique ABS pour le modèle SBS300P) - pompe à sec - panneau de commande numérique avec cycle de travail automatique et/ou manuel - soudure 5 mm.
Accessoires: boîtes gaufrés de différents formats - bobines gaufrées pour obtenir des boîtes de la longueur désirée.

DE Maschine zur Verlängerung der Aufbewahrungsdauer von Lebensmitteln, um die Integrität der organoleptischen Eigenschaften zu gewährleisten. Durch den Einsatz von geprägte Beutel oder Behälter wird ein Vakuumniveau erzeugt, dass die Keimenvermehrung verhindert. Edelstahlgehäuse (aus ABS-Kunststoff für das Modell SBS300P) - Trockenlaufpumpe - digitales Bedienfeld mit automatischem und/oder manuellem Arbeitszyklus - 5 mm Siegelung.
Zubehör: geprägte Beutel in verschiedenen Formaten - geprägte Rollen zur Herstellung von Beutel der gewünschten Länge.

ES Máquina para prolongar el tiempo de conservación de los alimentos manteniendo sus características organolépticas. A través del uso de bolsas o contenedores especiales crea un nivel de vacío tal que impida la proliferación de bacterias. Carcasa de acero inoxidable (de plástico ABS en el modelo SBS300P) - bomba seca et bara - panel de control digital con ciclos de trabajos manuales y/o automáticos - sellado de 5 mm. Accesorios: bolsas gofradas de diferentes tamaños - rollos gofrados para obtener bolsas de diferentes medidas.

RU Машина для продления срока хранения продуктов. обеспечение целостности органолептических характеристик. Использование специальных тисненых конвертов или контейнеров создает уровень вакуума, предотвращающий размножение бактерий. Корпус из нержавеющей стали (ABS пластик для модели SBS300P) - сухой насос - цифровая панель управления с автоматическим и/или ручным циклом работы - 5 мм уплотнение.
Аксессуары: тисненные пакеты различных размеров - тисненные рулоны для получения пакетов нужной длины.

	ABX-SBS300P	ABX-SBP350	ABX-SBP400
	0,19 kW (0,25 HP)	0,25 kW (0,33 HP)	0,27 kW (0,36 HP)
	230V/1N/50Hz		
BARRA SILDANTE/ HOT-WELD SEALER	300 mm	350 mm	400 mm
POMPA VUOTO/ VACUUM PUMP	0,6 m³/h	1,2 m³/h	
VUOTO MAX OTTENIBILE/ MAX ACHIEVABLE VACUUM	80%		
	380 x 180 x 80(h) mm	370 x 260 x 130(h) mm	420 x 260 x 130(h) mm
	2 Kg	7,5 Kg	8 Kg
	2,5 Kg	8,2 Kg	9 Kg
	440 x 260 x 120(h) mm	420 x 290 x 210(h) mm	510 x 330 x 240(h) mm
	0,014 m³	0,026 m³	0,040 m³
	200 €	490 €	590 €
	Special Voltages - Разное питающее напряжение + 65 €		

* Utilizzare solo buste per sottovuoto goffrate.
Use only embossed bags.
Utiliser seulement les sachets gaufrés.
Nur gaufrierte Beutel fuer vakuum benutzen.
Usar solo bolsas para envasado al vacío gofradas.
Использовать только пакеты для вакуума с тиснением

OPTIONAL



ABX-SCC300
ABX-SBS300P
ABX-SBP350
ABX-SBP400



ABX-SCC300



ABX-SBS300P



ABX-SBP350



ABX-SBP400

Optional
macchine sottovuoto

Mod.		Confezione per scatola Packages per box Boîtes par carton Päckchen pro Karton Paquetes por caja Упакуйте в коробку	100 pz. Confezione 100 pcs. Pack 100 pièces par paquet. 100 Stk. Packung. 100 uds. por caja 100 шт. в упаковке	Scatola Box Carton Karton Caja Коробка
µm 105 Buste Goffrate Embossed bags Boîtes gaufrées Geprägte Beutel Bolsas gofradas Рельефные сумки	15 x 30 cm	20	18 €	305 €
	20 x 30 cm	16	24 €	322 €
	20 x 40 cm	12	29 €	319 €
	25 x 35 cm	10	33 €	303 €
	30 x 40 cm	8	44 €	321 €
	30 x 50 cm	5	54 €	249 €
	40 x 60 cm	4	87 €	316 €
	50 x 70 cm	4 (50 pz - pcs - stück - unidades - шт.)	64 €	237 €
2 rotoli - 2 rolls - 2 rouleaux 2 Rollen - 2 rollos - 2 рулонов	20 x 600 cm	-		17 €
	30 x 600 cm	-		25 €
µm 105 Buste goffrate per cottura Embossed cooking bags Boîtes gaufrées pour cuisson Geprägte Kochbeutel Bolsas gofradas para la cocción Рельефные варочные пакеты	15 x 30 cm	20	34 €	614 €
	20 x 30 cm	16	44 €	644 €
	20 x 40 cm	12	59 €	638 €
	25 x 35 cm	10	64 €	581 €
	30 x 40 cm	8	87 €	638 €
	30 x 50 cm	5	108 €	497 €
	40 x 60 cm	4	173 €	635 €
90 µm Buste lisce - Smooth bags Boîtes lisses - Glatte Beutel Bolsas lisas - Гладкие сумки	20 x 30 cm	20	21 €	386 €
	25 x 35 cm	16	31 €	443 €
	30 x 40 cm	10	42 €	374 €
	40 x 50 cm	6	76 €	414 €
90 µm Buste lisce per cottura Smooth cooking bags Boîtes lisses pour cuisson Glatte Kochbeutel Bolsas lisas para la cocción Гладкие пакеты для готовки	15 x 30 cm	25	33 €	694 €
	20 x 30 cm	20	43 €	618 €
	25 x 35 cm	16	62 €	678 €
	30 x 40 cm	10	85 €	770 €
	40 x 60 cm	5	168 €	770 €
	50 x 60 cm	3.5	211 €	678 €

ABX-TM905+Q109

ABX-TM1128



ABX-TM905



ABX-Q109

















ABX-TM1128

**Frullatori
con funzione cottura**



- IT** Macchine per la preparazione di zuppe, riduzioni e salse. Pannello touch screen con programmi pre-impostati.
 TM905+Q109: Macchina compresa di cutter manuale - bicchiere in vetro.
 TM1128: Bicchiere in acciaio inox.
- EN** The ideal machines to prepare soups, reductions and sauces. Touch screen panel with pre-set programs.
 TM905+Q109: The machine is equipped with a manual cutter and a glass cup.
 TM1128: Stainless steel cup.
- FR** Machines pour la préparation de soupes, réductions et sauces. Ecran tactile avec programmes prédéfinis.
 TM905+Q109: Machine avec découpeur manuel - récipient en verre.
 TM1128: récipient en acier inox.
- DE** Suppen-, Reduktions- und Saucenzubereitungsmaschinen. Touchscreen-Bedienfeld mit voreingestellten Programmen.
 TM905+Q109: Maschine mit Handschneider - Glasbecher.
 TM1128: Edelstahlbecher.
- ES** Máquina para preparar sopas, reducciones y salsas. Panel "touch screen" con programas preestablecidos.
 TM905+q109: Máquina que incluye un cutter manual - vaso de vidrio.
 TM1128: Vaso de acero inoxidable.
- RU** Идеальные машины для приготовления супов, редукторов и соусов. Сенсорная панель с предустановленными программами.
 TM905+Q109: Машина оснащена ручным резаком и стеклянной чашкой. TM1128: Чашка из нержавеющей стали.

	ABX-TM905 + Q109		ABX-TM1128
	1 kW	0,2 kW	1 kW
	220-240V/1N/50-60Hz		
HEATING POWER	1,2 kW	-	1,2 kW
	Max 100°C	-	Max 100°C
	26000 rpm	24000 rpm	26000 rpm
	1,75 L	-	1,75 L
	250 x 195 x 503(h) mm	225 x 206 x 267(h) mm	270 x 200 x 505(h) mm
			
	7,5 Kg		4,5 Kg
	10,8 Kg		6 Kg
	467 x 467 x 327(h) mm		573 x 475 x 245(h) mm
	0,071 m³		0,066 m³
			
	822 €		730 €

ABX-CS1107

ABX-CS1109



CS1109



CS1107

**Frullatori
con insonorizzatore**



IT Macchine per preparare frullati, frappè ecc. Pannello touch screen con possibilità di programmi pre-impostati - insonorizzatore integrato nel basamento della macchina - bicchiere in lexan trasparente da 2 L.

EN Machines to prepare milkshakes, smoothies, etc. Touch screen panel with optional pre-set programmes - sound-proofer integrated in the machine base - 2 L clear lexan cup.

FR Machines pour la préparation de milkshakes, laits frappés, etc. Ecran tactile avec possibilité de programmes pré-réglés - insonorisation intégrée dans le bâti de la machine - récipient lexan transparent 2 litres.

DE Maschinen zur Herstellung von Smoothies, Milchshakes, etc. Touchscreen-Bedienfeld mit Voreinstellungsmöglichkeit - Schallschutz im Maschinenbett integriert - 2 L klarer lexanbecher.

ES Máquina para preparar batidos, granizados, etc. Panel "touch screen" con programas preestablecidos - insonorizador integrado en el cárter - vaso (capacidad 2 litros) de lexan transparente.

RU Машины для приготовления молочных коктейлей, коктейлей и т.д. Сенсорная панель с дополнительными предустановленными программами - звукоизоляция, встроенная в основание станка - 2 л прозрачная чашка lexan.

	ABX-CS1107	ABX-CS1109
	1,8 kW	
 1 Ph	220-240V/1N/50-60Hz	
 RPM	30000 rpm	
	2 L	
 mm	239 x 229 x 461(h) mm	302 x 202 x 468(h) mm
		
 Kg	7,5 Kg	5,4 Kg
 Kg	8 Kg	7,2 Kg
 mm	550 x 300 x 300(h) mm	348 x 245 x 617(h) mm
 m ³	0,073 m ³	0,052 m ³
		
	430 €	430 €



ABX-PB009
ABX-PU008



ABX-PB009



ABX-PU008

Estrattore di succhi



IT Macchine per ottenere succhi di frutta e verdura mantenendo intatti gli elementi nutritivi naturalmente presenti nel cibo grazie al sistema di estrazione a bassa velocità (slow juicer). Struttura in acciaio inox e plastica idonea agli alimenti - espulsione automatica della polpa. In dotazione 2 contenitori in plastica per gli scarti e per il succo, 1 filtro, box per la preparazione del tofu, spazzolino per la pulizia, 3 filtri in acciaio inox. PB009: esclusivo imbuto a bocca larga che permette l'introduzione di frutta e verdura intere, senza bisogno di sminuzzarle grazie ad una dimensione della bocca di Ø 80 mm. PU008: tasto funzione reverse per una facile e veloce pulizia - dimensione della bocca Ø 40 mm - 45 rpm di velocità.

EN Machine to obtain fruit and vegetable juices while keeping intact the nutrients naturally present in the food thanks to the slow juicer system. Casing in stainless steel and plastic suitable for food - automatic pulp ejection. Supplied with 2 plastic containers for waste and juice, 1 filter, box for the preparation of tofu, cleaning brush, 3 stainless steel filters. PB009: Extremely wide inlet funnel that allows the introduction of whole fruits and vegetables, with no need to cut them into pieces thanks to an inlet size of Ø 80 mm. PU008: reverse function switch for quick and easy cleaning - inlet size Ø 40 mm - 45 rpm speed

FR Machines pour obtenir des jus de fruits et de légumes tout en conservant intacts les nutriments naturellement présents dans l'aliment grâce au système d'extraction à basse vitesse (slow juicer). Corps en acier inox et en plastique alimentaire - expulsion automatique de la pulpe. Livré avec 2 récipients en plastique pour les déchets et le jus, 1 filtre, boîte pour la préparation du tofu, brosse pour le nettoyage, 3 filtres en acier inox. PB009: Entonnoir à grande orifice qui permet l'introduction de fruits et légumes entiers, sans devoir les écraser grâce à une ouverture de Ø 80 mm. PU008 : touche de fonction inverse pour un nettoyage rapide et Ø 40 mm - vitesse de 45 tr/min facile - taille de l'orifice

DE Maschinen zur Zubereitung von Frucht- und Gemüsesäften unter Beibehaltung der natürlichen Nährstoffe durch das langsame Extraktionssystem (Slow Juicer). Edelstahl- und lebensmitteltauglich Kunststoffgehäuse - automatisches Ausstoßen der Pulpe. Ausgestattet mit 2 Kunststoffbehältern für Abfall und Saft, 1 Filter, Box zur Zubereitung von Tofu, Bürste zur Reinigung, 3 Edelstahlfilter. PB009: Exklusiver Trichter mit extra Größe Einfuhröffnung, zur Einführung von ganzen Obst und Gemüse, ohne vorheriges Zerkleinern, dank einer Öffnungsweite von Ø 80 mm. PU008: Umkehrfunktionstaste für schnelle und einfache Reinigung - Einführungsöffnungsgröße Ø 40 mm - Drehzahl 45 U/min.

ES Máquinas para la preparación de zumos de frutas y verduras manteniendo los nutrientes naturales a través del sistema de extracción lenta (Slow Juicer). Carcasa de acero inoxidable y plástico apto para uso alimentario - Expulsión automática de la pulpa. Equipado con 2 contenedores de plástico para residuos y zumos, 1 filtro, caja para la preparación de tofu, cepillo para la limpieza, 3 filtros de acero inoxidable. PB009: Embudo exclusivo con abertura de entrada extremadamente grande, para la introducción de frutas y hortalizas enteras, sin trituración previa, gracias a un ancho de abertura de Ø 80 mm. PU008: tecla de función de reversa para una limpieza rápida y fácil - tamaño de la boca Ø 40 mm - velocidad de 45 rpm.

RU Машины для приготовления фруктовых и овощных соков с сохранением натуральных питательных веществ благодаря системе медленной экстракции (Slow Juicer). Корпус из нержавеющей стали и пищевого пластика - автоматический выброс отходов. Оснащен 2 пластиковыми контейнерами для отходов и сока, 1 фильтром, коробкой для приготовления тофу, щеткой для очистки, 3 фильтрами из нержавеющей стали. В009: Эксклюзивная воронка с чрезвычайно большим входным отверстием, для вставки цельных фруктов и овощей, без предварительного дробления, благодаря ширине отверстия Ø 80 мм. PU008: обратная функциональная клавиша для быстрой и легкой чистки - размер рта Ø 40 мм - скорость вращения 45 об/мин

	ABX-PB009	ABX-PU008
	0,4 kW	0,25 kW
	220-240V/1N/50-60 Hz	
	37 rpm	45 rpm
	250 x 160 x 450(h) mm	150 x 250 x 450(h) mm
	9 Kg	8,5 Kg
	10 Kg	9,5 Kg
	340 x 370 x 290(h) mm	
	0,036 m³	
	430 €	362 €



ABX-CJ900

ABX-PC700



ABX-CJ900



ABX-PC700

PROFESSIONAL

Centrifuga



IT Macchina per realizzare centrifugati di frutta e verdura - struttura in acciaio inox e plastica idonea al contatto con gli alimenti - espulsione automatica della polpa - dimensione bocca \varnothing 70 mm PC700- dimensione bocca \varnothing 80 mm CJ900- contenitore scarti in plastica - microinterruttore di sicurezza su aggancio coperchio superiore - vasca, filtro e disco in acciaio inox.

EN Machine designed to produce fruit and vegetable centrifuges - casing made of stainless steel and plastic suitable for contact with food - automatic pulp ejection - inlet size \varnothing 70 mm for PC700 - inlet size \varnothing 80 mm for CJ900 - plastic waste container - safety microswitch on upper lid fastening - stainless steel bowl, filter and disk.

FR Machine pour la préparation de produits centrifugés à base de fruits et légumes - corps en acier inox et plastique apte au contact alimentaire - éjection automatique de la pulpe - PC700 dimension orifice \varnothing 70 mm - CJ900 dimension orifice \varnothing 80 mm - récipient pour les déchets en plastique - microrupteur de sécurité sur le couvercle supérieur - cuve, filtre et disque en acier inox.

DE Maschine zur Herstellung von Obst- und Gemüsezentrifugen - Edelstahl- und Kunststoffstruktur geeignet für den Kontakt mit Lebensmitteln - automatischer Ausstoß der Pulpe - PC700 Einführöffnungsgröße \varnothing 70 mm - CJ900 Einführöffnungsgröße \varnothing 80 mm - Kunststoffabfallbehälter - Sicherheitsmikroschalter am Oberdeckelaufsatz - Behälter, Filter und Scheibe aus Edelstahl.

ES Máquina para preparar centrifugas de frutas u hortalizas - estructura de acero inoxidable y plástico idóneo para el contacto con los alimentos - expulsión automática de la pulpa - PC700 boca de \varnothing 70 mm - CJ900 boca de \varnothing 80 mm - recipiente para los residuos de plástico - microinterruptor de seguridad en el enganche de la tapa - cuba, filtro y disco de acero inoxidable.

RU Машина предназначена для производства фруктовых и овощных centrifug - корпус из нержавеющей стали и пластика, пригодный для контакта с пищевыми продуктами - автоматический выброс мякоти - PC700 входной размер \varnothing 70 мм - CJ900 входной размер \varnothing 80 мм - пластиковый контейнер для отходов - микровыключатель безопасности на креплении верхней крышки - резервуар, фильтр и диск из нержавеющей стали.

	ABX-CJ900	ABX-PC700
	0,7 kW	0,85 kW
	220-240V/1N/50-60Hz	
	3000 rpm	2800 rpm
	473 x 253 x 525(h) mm	230 x 310 x 395(h) mm
	13,3 Kg	5 Kg
	15 Kg	6 Kg
	490 x 280 x 520(h) mm	330 x 270 x 440(h) mm
	0,071 m ³	0,039 m ³
	1.110 €	100 €



ABX-DMB
ABX-DMB20



Fruillatori frappé



IT Macchina per realizzare frappè, cocktails, sorbetti, ecc. Base e corpo motore in alluminio, colonna in acciaio inox - bicchiere in acciaio inox da 0,8 L - sistema di accensione automatica solo con bicchiere inserito.

EN Machine to prepare milkshakes, cocktails, Sorbet, etc. Base and motor unit in aluminium, pole in stainless steel - 0,8 L Stainless steel cup - automatic ignition system only with inserted cup.

FR Appareil permettant de préparer des frappés, cocktails, sorbets, etc. Base et corps moteur en aluminium, colonne en acier inox - récipient de 0,8 L en acier inox - système de démarrage automatique uniquement si le récipient est inséré.

DE Maschine zur Herstellung von Milchshakes, Cocktails, Sorbets, etc. Sockel und Motorkörper aus Aluminium, Säule aus Edelstahl - 0,8 L Becher aus Edelstahl - automatisches Einschaltungssystem nur bei eingesetztem Becher.

ES Máquina para preparar batidos, coctéles, sorbetes, etc. Base y cuerpo motor de aluminio, columna de acero inoxidable - vaso (capacidad 0,8 litros) de acero inoxidable - sistema de encendido automático sólo si el vaso está enganchado.

RU Машина для приготовления молочных коктейлей, коктейлей, сорбента и т.д... Базовый блок и моторный блок из алюминия, стойка из бесстатистической стали - 0,8 л. Чашка из нержавеющей стали - автоматическая система зажигания только со вставленной чашкой.

	ABX-DMB	ABX-DMB20
	0,4 kW	0,4 + 0,4 kW
 1 Ph	220-240V/1N/50-60Hz	
 RPM	16000 rpm	16000 + 16000 rpm
	0,8 L	0,8 + 0,8 L
 mm	200 x 230 x 500(h) mm	330 x 160 x 500(h) mm
		
 NET Kg	3,6 Kg	7,5 Kg
 GROSS Kg	4,5 Kg	9 Kg
 mm	300 x 260 x 530(h) mm	600 x 260 x 530(h) mm
 m ³	0,042 m ³	0,083 m ³
		
	180 €	372 €



ABX-BL020
ABX-BL020B



ABX-BL020B



ABX-BL020

Frullatori



IT Macchine per la preparazione di frullati - bicchiere in lexan trasparente da 2 L - tappo sul coperchio per aggiungere ingredienti in fase di lavoro - coltello a 4 lame in acciaio inox - microinterruttore di sicurezza sul bicchiere.
 BL020: Carcassa in plastica - motore a due velocità - 4 programmi memorizzati (8-12-30-60") - tasto "pulse" lento e veloce - tasto tritaggiaccio.
 BL020B: Carcassa in plastica cromata - regolatore di velocità - tasto "pulse".

EN Smoothie makers - 2 L clear lexan cup - cap on the lid to add ingredients during use - 4-blade stainless steel knife - safety microswitch on the cup.
 BL020: Plastic casing - two-speed motor - 4 stored programs (8-12-30-60") - slow and fast "pulse" button - ice crusher button.
 BL020B: Chrome-plated plastic casing - speed controller - "pulse" button.

FR Machines à smoothie - récipient en lexan transparent de 2 L - bouchon sur le couvercle pour ajouter les ingrédients pendant la préparation - couteau à 4 lames en acier inox - micro-interrupteur de sécurité sur le récipient.
 BL020: Corps en plastique - moteur à deux vitesses - 4 programmes mémorisés (8-12-30-60") - touche "pulse" lente et rapide - bouton broyeur de glace.
 BL020B: Corps en plastique chromé - variateur de vitesse - touche "pulse".

DE Smoothie Maschinen - 2 L klarer lexanbecher -4-Klingen-Edelstahlmesser - Deckelkappe zum Hinzufügen von Zutaten während der Vorbereitung - Sicherheitsmikroschalter am Becher.
 BL020: Kunststoffgehäuse - Motor mit zwei Geschwindigkeiten - 4 gespeicherte Programme (8-12-30-60") - "Pulse"-Taste langsam und schnell - Eisbrecher-Taste.
 BL020B: Verchromtes Kunststoffgehäuse - Drehzahlregler - Taste "Pulse".

ES Máquina para preparar batidos de fruta - vaso de lexan transparente (capacidad 2 litros) - tapón en la tapa para añadir los ingredientes durante el funcionamiento - cuchillo con 4 cuchillas de acero inoxidable - microinterruptor de seguridad en el vaso.
 BL020: carcasa de plástico - motor de dos velocidades - 4 programas preestablecidos (8-12-30-60") - botón "pulse" lento y rápido - botón picador de hielo.
 BL020B: carcasa de plástico cromado - regulador de velocidad - botón "pulse".

RU Машины для приготовления коктейлей - 2 л прозрачного тощего стекла. - крышка на крышке для добавления ингредиентов во время работы - 4 ножа из нержавеющей стали - безопасный микровыключатель на стекле.
 BL020: пластиковый корпус - двухскоростной двигатель - 4 сохраненные программы (8-12-30-60") - медленный и быстрый "импульсный" ключ - ключ дробилки льда.
 BL020B: Хромированный пластиковый корпус - регулятор скорости - "импульсная" клавиша.

	ABX-BL020	ABX-BL020B
	1,5 kW	
	220-240V/1N/50-60Hz	
	28000 rpm	
	2 L	
	200 x 260 x 520(h) mm	190 x 220 x 490(h) mm
	5 Kg	4,2 Kg
	6 Kg	5,2 Kg
	330 x 260 x 530(h) mm	
	0,045 m³	
	339 €	290 €

BINOX Bicchiere in acciaio inox - Stainless steel cup - Récipient acier inox Edelstahlbecher - Vaso de acero inoxidable - Нержавеющая сталь Стекло	
	145 €

ABX-BL021

ABX-BI0008



ABX-BL021













ABX-BL008

Frullatori



- IT** Macchine per la preparazione di frullati - bicchiere in lexan trasparente da 2 L - regolatore di velocità - tasto "pulse" - microinterruttore di sicurezza sul bicchiere - coltello a 4 lame in acciaio inox - tappo sul coperchio per aggiungere ingredienti in fase di lavoro.
BL021: Carcassa in acciaio inox.
BL008: Carcassa in plastica.
- EN** Milkshake makers 2 L clear lexan cup - speed regulator - "pulse" button - safety microswitch on the cup - 4-blade stainless steel knife - cap on the lid to add ingredients during use.
BL021:Stainless steel casing.
BL008:Plastic casing.
- FR** Machines à smoothie - récipient en lexan transparent de 2 L - variateur de vitesse - touche "pulse" - micro-interrupteur de sécurité sur le récipient - couteau à 4 lames en acier inox - bouchon sur le couvercle pour ajouter les ingrédients pendant la préparation.
BL021: Corps en acier inox.
BL008: Corps en plastique.
- DE** Smoothie Maschinen - 2 L klarer lexanbecher - Drehzahlregler - Taste "Pulse" - Sicherheitsmikroschalter am Becher - 4-Klingen-Edelstahlmesser - Deckelkappe zum Hinzufügen von Zutaten während der Vorbereitung.
BL021: Edelstahlgehäuse.
BL008: Kunststoffgehäuse.
- ES** Máquina para preparar batidos de fruta - vaso de lexan transparente (capacidad 2 litros) - regulador de velocidad - botón "pulse" - microinterruptor de seguridad en el vaso - cuchillo con 4 cuchillas de acero inoxidable - tapón en la tapa para añadir los ingredientes durante el funcionamiento.
BL021: carcasa de acero inoxidable.
BL008: carcasa de plástico.
- RU** Машины для приготовления коктейлей - 2 литра прозрачного тощего стекла - регулятор скорости - кнопка "импульс" - предохранительный микровыключатель на панели управления стекло - 4-лопастной нож из нержавеющей стали - колпачок на крышке для добавления ингредиентов во время работы.
BL021: Корпус из нержавеющей стали
BL008: Пластиковый корпус.

	ABX-BL021	ABX-BL008
	1,5 kW	1 kW
	220-240V/1N/50-60Hz	
	28000 rpm	
	2 L	
	200 x 260 x 520(h) mm	190 x 230 x 510(h) mm
		
	5,2 Kg	4 Kg
	6,5 Kg	5 Kg
	330 x 260 x 530(h) mm	
	0,045 m³	
		
	290 €	180 €
BINOX Bicchiere in acciaio inox - Stainless steel cup - Récipient acier inox Edelstahlbecher - Vaso de acero inoxidable - Нержавеющая сталь Стекло		
		
non disponibile per BL008 not available for BL008 не доступно для модели BL008		
	145 €	

ABX-SMCJ4

ABX-SMCJ6



Spremiagrumi



IT Macchine per spremere agrumi.

SMCJ4: Spremiagrumi elettrico in lega di alluminio verniciato - vasca, filtro, paraspruzzi e pigna in plastica estraibili - tripla pigna.

SMCJ6: Spremiagrumi elettrico a leva in lega di alluminio satinato - azionamento e spegnimento tramite l'utilizzo della leva premi agrumi - vasca, filtro, pigna e paraspruzzi removibili in acciaio inox.

EN Citrus juicers.

SMCJ4: Electric citrus juicer in painted aluminium alloy - removable plastic bowl, filter, backsplash and reamer - triple reamer.

SMCJ6: Electric citrus juicer with lever in satin aluminium alloy - ON / OFF by means of the citrus juicer lever - removable stainless steel bowl, filter, reamer and backsplash.

FR Machines à presser les agrumes.

SMCJ4: Extracteur de jus d'agrumes électrique en alliage d'aluminium peint - cuve, filtre, dosseret et cônes amovibles en plastique - triple cône.

SMCJ6: Presse-agrumes électrique avec levier en alliage d'aluminium satiné - marche et arrêt par pression du levier - cuve, filtre, cône et dosseret amovibles en acier inox.

DE Zitruspressenmaschinen.

SMCJ4: Elektrische Zitruspresse aus lackierter Aluminiumlegierung - abnehmbare Wanne, Filter, Spritzschutz und Kegel aus Kunststoff - Dreifachkegel.

SMCJ6: Elektrische Zitruspresse mit Hebel aus satinierter Aluminiumlegierung - Ein- und Ausschaltung über Druckhebel - abnehmbare Wanne, Filter, Kegel und Spritzschutz aus Edelstahl.

ES Máquina para exprimir cítricos.

SMCJ4: Exprimidor eléctrico de aleación de aluminio pintado - cuba, filtro, protección y conos extraíbles - 3 conos.

SMCJ6: Exprimidor eléctrico (de aleación de aluminio pulido) de palanca - puesta en marcha y apagado a través de una palanca que presiona los frutos - cuba, filtro, protección y conos extraíbles y de acero inoxidable.

RU Машины для прессования citrusовых фруктов.

SMCJ4: Электрическая соковыжималка для citrusовых из окрашенного алюминиевого сплава - бак, фильтр, люфт и съемные пластиковые конусы - тройной конус.

SMCJ6: Электрическая соковыжималка для citrusовых с рычагом из алюминиевого сплава с атласным покрытием - рычаг включения/выключения - съемный бак, фильтр, конус и спинка из нержавеющей стали.

	ABX-SMCJ4	ABX-SMCJ6
	0,18 kW	0,23 kW
 1 Ph	220-240V/1N/50-60Hz	
 RPM	1800 rpm	980 rpm
 mm	220 x 310 x 340(h) mm	220 x 290 x 390/585(h) mm
		
 NET Kg	5 Kg	8,7 Kg
 GROSS Kg	5,5 Kg	9,7 Kg
 mm	310 x 220 x 360(h) mm	360 x 280 x 470(h) mm
 m ³	0,024 m ³	0,047 m ³
		
	190 €	380 €



ABX-SMCJ5
ABX-SMCJ5A



Spremiagrumi



IT Macchine per spremere agrumi.

SMCJ5: Spremiagrumi elettrico in lega di alluminio satinato - vasca, filtro, paraspruzzi e pigne in plastica estraibili - tripla pigna.

SMCJ5A: Spremiagrumi elettrico a leva in lega di alluminio satinato - azionamento e spegnimento tramite l'utilizzo della leva premi agrumi - vasca, pigna e filtro in plastica - paraspruzzi in acciaio inox.

EN Citrus juicers.

SMCJ5: Electric citrus juicer in painted aluminium alloy - removable plastic bowl, filter, backsplash and reamer - triple reamer.

SMCJ5A: Electric citrus juicer with lever in satin aluminium alloy - ON / OFF by means of the citrus juicer lever - plastic bowl, filter and reamer stainless steel backsplash.

FR Machines à presser les agrumes.

SMCJ4: Extracteur de jus d'agrumes électrique en alliage d'aluminium satiné - cuve, filtre, dosseret et cônes amovibles en plastique - triple cône.

SMCJ6: Presse-agrumes électrique avec levier en alliage d'aluminium satiné - marche et arrêt par pression du levier - cuve, filtre et cône en plastique, dosseret en acier inox.

DE Zitruspressenmaschinen.

SMCJ5: Elektrische Zitruspresse aus satiniertes Aluminiumlegierung - abnehmbare Wanne, Filter, Spritzschutz und Kegel aus Kunststoff - Dreifachkegel.

SMCJ5A: Elektrische Zitruspresse mit Hebel aus satiniertes Aluminiumlegierung - Ein- und Ausschaltung über Druckhebel - Wanne, Filter und Kegel aus Kunststoff und Spritzschutz aus Edelstahl.

ES Máquina para exprimir cítricos.

SMCJ5: Exprimidor eléctrico de aleación de aluminio pintado - cuba, filtro, protección y conos extraíbles - 3 conos.

SMCJ6: Exprimidor eléctrico (de aleación de aluminio pulido) de palanca - puesta en marcha y apagado a través de una palanca que presiona los frutos - cuba, filtro, protección y conos extraíbles y de acero inoxidable.

RU Соковыжималки для цитрусовых.

SMCJ5: Электрическая соковыжималка для цитрусовых из окрашенного алюминиевого сплава - съемная пластиковая емкость, фильтр, обратная зазор и развертка - тройная развертка.

SMCJ5A: Электрическая соковыжималка для цитрусовых с рычагом из атласного алюминиевого сплава - ON / OFF с помощью рычага соковыжималки - пластиковой чаши, фильтра и разбрызгивателя из нержавеющей стали.

	ABX-SMCJ5	ABX-SMCJ5A
	0,18 kW	0,23 kW
	220-240V/1N/50-60Hz	
	1800 rpm	1450 rpm
	340 x 202 x 420(h) mm	335 x 202 x 475/680(h) mm
	5,5 Kg	8 Kg
	6,5 Kg	8,8 Kg
	360 x 252 x 455(h) mm	380 x 240 x 510(h) mm
	0,042 m ³	0,047 m ³
	230 €	390 €



ABX-WM1

ABX-WM15



ABX-WM15



ABX-WM1

Waffle machine



IT Macchina per realizzare waffie. Struttura in acciaio inox - piastra di cottura tefflonata - termostato 50÷300°C - timer 0÷5 minuti.

EN Waffle machine. Stainless steel casing - Teflon cooking grill - thermostat 50÷300°C - 0÷5 minute timer.

FR Appareil pour préparer les gaufres. Corps en acier inox - plaque de cuisson en téflon - thermostat 50÷300°C - minuterie 0÷5 minutes.

DE Maschine zur Zubereitung von Waffeln. Edelstahlgehäuse - tefflonbeschichtete Kochplatte - Thermostat 50÷300°C - Timer 0÷5 Minuten.

ES Máquina para preparar waffles. Estructura de acero inoxidable - placa para la cocción con teflón - termostato 50÷300°C - temporizador 0÷5 minutos.

RU Вафельная машина. Корпус из нержавеющей стали - Тefлоновый гриль - термостат 50÷300°C - таймер 0÷5 минут.

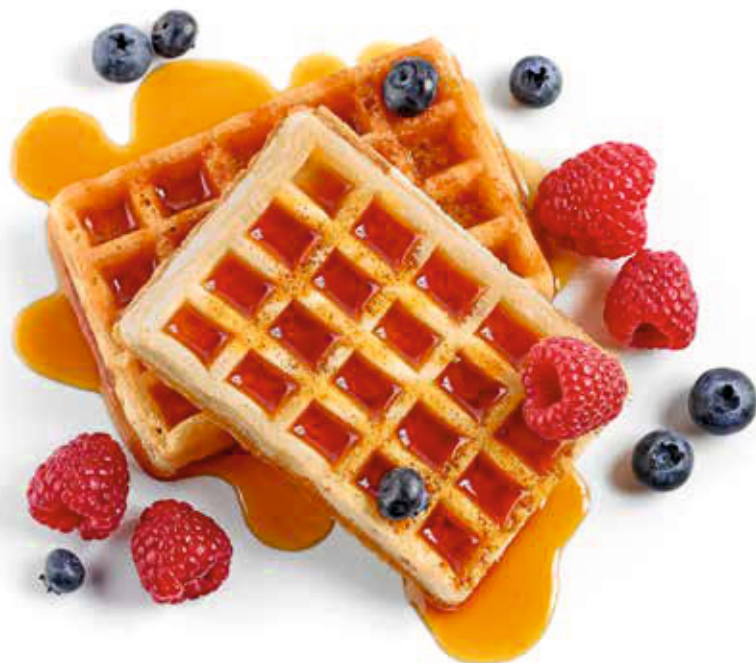

	ABX-WM1	ABX-WM15
	1 kW	1,5 kW
 1 Ph	220-240V/1N/50-60Hz	
	50÷300°C	
	0÷5'	
 mm	ø 185 mm	275 x 245 mm
 mm	255 x 435 x 255/570(h) mm	340 x 370 x 240/580(h) mm
		
 Kg	6 Kg	11,5 Kg
 Kg	8 Kg	14,5 Kg
 mm	440 x 260 x 260(h) mm	390 x 430 x 320(h) mm
 m³	0,029 m³	0,054 m³
		
	218 €	340 €

ABX-ESTA3

ABX-CVT1



ABX-ESTA3



ABX-CVT1

Tostapane continuo



IT Tostapane per tostare pane a ciclo continuo. Struttura in acciaio inox - tappeto di tostatura girevole in acciaio inox - camera di cottura con isolamento termico - regolatore velocità di scorrimento tappeto di cottura (manuale per il mod. ESTA3, elettronico per il mod. CVT1) - 3 modalità accensione resistenze - modalità risparmio energetico (solo per ESTA3) - uscita del pane tostato frontale o posteriore - tempo di cottura 90÷340"

EN Continuous bread conveyor . Stainless steel casing - stainless steel rotating toasting conveyor - baking chamber with thermal insulation - toasting conveyor speed regulator (manual for ESTA3 model, electronic for CVT1 model) - 3 heating element ignition modes - energy saving mode (only for ESTA3) - front or rear toast outlet - cooking time 90÷340".

FR Convoyeur à pain continu . Corps en acier inox - convoyeur de grillage rotatif en acier inox - chambre de cuisson avec isolation thermique - régulateur de vitesse du convoyeur de grillage (manuel pour le modèle ESTA3, électronique pour le modèle CVT1) - 3 modes d'allumage des éléments chauffants - modalité économie d'énergie (uniquement pour ESTA3) - sortie du pain grille frontale ou arrière - temps de cuisson 90÷340".

DE Toaster zum ununterbrochene Toasten von Brot. Gehäuse aus Edelstahl - drehbares Toastband aus Edelstahl - Backkammer mit Wärmedämmung - Toastband-Gleitgeschwindigkeitsregler (manuell für Modell ESTA3, elektronisch für Modell CVT1) - 3 Zündarten der Heizelemente - Energiesparbetrieb (nur für ESTA3) - Vorder- oder Hintertoastauslass - Kochzeit 90÷340".

ES Tostadora para tostar el pan en proceso continuo. Estructura de acero inoxidable - tapete giratorio de acero inoxidable para tostar - cámara de cocción revestida con material aislante - regulación velocidad deslizamiento tapete de cocción (manual en el modelo ESTA3, electrónico en el modelo CVT1) - 3 modos para activar las resistencias - modo de ahorro de energía (solo modelo ESTA3) - salida del pan tostado anterior o posterior - tiempo de cocción 90÷340".

RU Непрерывный транспортер хлеба . Корпус из нержавеющей стали - вращающийся тостер из нержавеющей стали - камера выпечки с термоизоляцией - регулятор скорости тостера (ручной для модели ESTA3, электронный для модели CVT1) - 3 режима зажигания нагревательных элементов - энергосберегающий режим (только для ESTA3) - передний или задний выход тостов - время приготовления 90÷340".

	ABX-ESTA3	ABX-CVT1
	2,45 kW	1,3 kW
	220-240V/1N/50-60Hz	
	350 mm	180 mm
	n. 120÷350	n. 50÷150
	480 x 560 x 430(h) mm	340 x 690 x 400(h) mm
	27 Kg	14 Kg
	29 Kg	16 Kg
	500 x 520 x 440(h) mm	480 x 380 x 400(h) mm
	0,115 m³	0,072 m³
	1.030 €	760 €

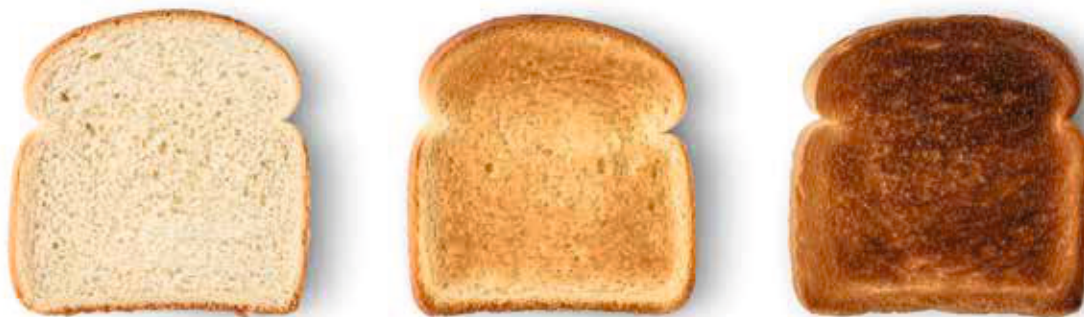

ABX-EG01
ABX-EG02
ABX-EG03
ABX-EG03M



ABX-EG01



ABX-EG03















ABX-EG03M

**Piaastre di cottura
in ghisa**



- IT** Macchina per cuocere e riscaldare carne, pesce, verdure, toast farciti, panini, ecc. Struttura in acciaio inox - piastra di cottura in ghisa - piastra superiore auto-bilanciata - piastre singole rigate - piastre doppie rigate (EG03) o miste (EG03M).
- EN** Meat, fish, vegetable, toast, sandwich, etc. heating and cooking appliance. Stainless steel casing - cast iron cooking grill - 50÷300°C thermostat - self-balanced upper plate - single plates rilled, double plates rilled (EG03) o mixed (EG03M).
- FR** Machine à cuire et à réchauffer la viande, le poisson, les légumes, les toasts farcis, les sandwiches, etc. Corps en acier inox - plaque de cuisson en fonte - plaque supérieure autocalibrée - plaques individuelles rainurées, plaques double rainurées (EG03) ou mixtes (EG03M).
- DE** Maschine zum Kochen und Erwärmen von Fleisch, Fisch, Gemüse, gefülltem Toast, Sandwiches, etc. Edelstahlstruktur - Kochplatte aus Gusseisen - selbstaushleichende Oberplatte - Einzelplatte glatt - Doppelplatte gerillt (EG03) oder kombiniert (EG03M).
- ES** Máquina para cocinar o calentar carne, pescado, verduras, tostadas, bocadillos, etc. Estructura de acero inoxidable - placa para la cocción de fundición - placa superior auto-equilibrada - placas individuales rayadas - placas dobles rayadas (EG03) o mixtas (EG03M).
- RU** Мясо, рыба, овощи, тосты, бутерброды и т.д., приборы для отопления и приготовления пищи. Корпус из нержавеющей стали - чугунный гриль - 50÷300°C термостат - самобалансирующаяся верхняя панель - одинарные, двойные жареные (EG03) или смешанные (EG03M) пластины.

	ABX-EG01	ABX-EG02	ABX-EG03 ABX-EG03M
	1,8 kW	2,2 kW	3,6 kW
 1 Ph	220-240V/1N/50-60Hz		
	50÷300°C		
 mm	240 x 230 mm	340 x 230 mm	475 x 230 mm
 mm	300 x 340 x 210/500(h) mm	410 x 305 x 210/500(h) mm	570 x 305 x 210/500(h) mm
			
 NET Kg	12,5 Kg	19 Kg	25 Kg
 GROSS Kg	14 Kg	21 Kg	32 Kg
 mm	360 x 460 x 280(h) mm	480 x 460 x 280(h) mm	630 x 460 x 410(h) mm
 m ³	0,047 m ³	0,062 m ³	0,115 m ³
			
	270 €	339 €	510 €



ABX-PFD20
ABX-PFD27N
ABX-PFD35N



ABX-PFD27N
ABX-PFD35N

**Piaastre
ad induzione**



- IT** Macchina con sistema di cottura ad induzione di calore dalla piastra al contenitore (di tipo metallico). Struttura in acciaio inox (in plastica per mod. PFD20) - piastra in vitroceramica - funzionamento in modalità livelli di potenza o in modalità temperatura - timer digitale.
- EN** Machine with heat induction cooking system from the plate to the container (of metal). Stainless steel casing (plastic for PFD20 model) - glass-ceramic plate - operation in power level mode or in temperature mode - digital timer.
- FR** Machine avec système de cuisson à induction de la plaque au récipient (de type métallique). Corps en acier inox (en plastique pour le modèle PFD20) - plaque vitrocéramique - fonctionnement en mode puissance ou en mode température - minuterie numérique.
- DE** Maschine mit Wärmeinduktionskochsystem von der Platte bis zum Behälter (Metallausführung). Gehäuse aus Edelstahl (aus Kunststoff für Modell PFD20) - Glaskeramikplatte - Leistungsstufen- oder Temperaturbetrieb - digitaler Timer.
- ES** Máquina con sistema de cocción a través de inducción de calor de la placa al recipiente (de metal). Estructura de acero inoxidable (de plástico con el modelo PFD20) - placa de vitrocerámica - funcionamiento con el modo nivel de potencia o con el modo temperatura - temporizador digital.
- RU** Машина с индукционной системой нагрева от плиты до емкости (из металла). Корпус из нержавеющей стали (пластик для модели PFD20) - стеклокерамическая пластина - работа в режиме уровня мощности или в температурном режиме - цифровой таймер.

	ABX-PFD20	ABX-PFD27N	ABX-PFD35N
	2 kW	2,7 kW	3,5 kW
	230V/1N/50Hz		
	ø 118 ÷ ø 220 mm	ø 140 ÷ ø 220 mm	
	290 x 370 x 44(h) mm	325 x 370 x 105(h) mm	343 x 440 x 120(h) mm
			
	2,3 Kg	5 Kg	8 Kg
	2,8 Kg	8 Kg	11 Kg
	450 x 390 x 100(h) mm	430 x 370 x 160(h) mm	510 x 420 x 190(h) mm
	0,018 m³	0,025 m³	0,041 m³
			
	100 €	240 €	345 €



ABX-PFD20

ABX-BT350W
ABX-WOK





ABX-BT350W

**Piastra a induzione
con wok**



- IT** Macchina con sistema di cottura ad induzione di calore dalla piastra al contenitore (di tipo metallico) per pentola WOK (da ordinare separatamente). Struttura in acciaio inox - piastra in vetroceramica - funzionamento in modalità livelli di potenza o in modalità temperatura - timer digitale.
- EN** Machine with heat induction cooking system from the plate to the container (of metal) equipped with WOK (to be ordered separately). Stainless steel casing - glass-ceramic plate - operation in power level mode or in temperature mode - digital timer.
- FR** Machine avec système de cuisson à induction de la plaque au récipient (de type métallique) équipé de WOK (sur commande spécifique). Corps en acier inox - plaque vitrocéramique - fonctionnement en mode puissance ou en mode température - minuterie numérique.
- DE** Maschine mit Wärmeinduktionskochsystem von der Platte bis zum Behälter (Metallausführung) ausgestattet mit Wok -Topf (extra zu bestellen). Gehäuse aus Edelstahl Glaskeramikplatte - Leistungsstufen- oder Temperaturbetrieb - digitaler Timer.
- ES** Máquina con sistema de cocción a través de inducción de calor de la placa al recipiente (de metal) equipado con wok (a pedir a parte). Estructura de acero inoxidable - placa de vitrocerámica - funcionamiento con el modo nivel de potencia o con el modo temperatura - temporizador digital.
- RU** Машина с индукционной системой нагрева от плиты до емкости (из металла) с горшком вок (заказывается отдельно). Корпус из нержавеющей стали - стеклокерамическая пластина - работа в режиме уровня мощности или в температурном режиме - цифровой таймер.

	ABX-BT350W	ABX-WOK
	3,5 kW	-
	230V/1N/50Hz	-
	ø 140 ÷ ø 220 mm	ø 360 mm
	343 x 440 x 120(h) mm	-
		
	8 Kg	2,9 Kg
	11 Kg	3,5 Kg
	510 x 420 x 190(h) mm	480 x 470 x 140(h) mm
	0,041 m³	0,031 m³
		
	350 €	140 €



ABX-WOK

ABX-SLB5
ABX-SLB7



Impastatrice planetaria



IT Macchina per diversi tipi di impasto quali pizza, pane, biscotti, croissant, brioches, bigné, pan di spagna, pasta frolla, meringhe, puree, salse varie, panna montata. Struttura in acciaio inox satinato - 1 vasca da 5 L per la SLB5 e da 7 L per la SLB7 - 3 utensili in dotazione, uncino, spatola e frusta tutti in acciaio inox - regolatore di velocità. Accessori: Vasca supplementare.

EN Machine for different types of dough such as pizza, bread, biscuits, croissants, brioches, cream puffs, sponge cake, shortcrust pastry, meringues, purees, various sauces, whipped cream, etc. Satin stainless steel casing - 1 x 5-litre bowl for the SLB5 and 1 x 7-litre bowl for the SLB7 - 3 tools supplied: hook, spatula and whisk all made of stainless steel -speed regulator. Accessories: additional basin.

FR Machine pour différents types de pâte tels que pizza, pain, biscuits, croissants, brioches, pains à la crème, gâteau éponge, pâte brisée, meringues, purées, sauces, crème fouettée, etc. Corps en acier inox satiné -1 cuve de 5 litres pour le SLB5 et 1 cuve de 7 litres pour le SLB7 - 3 outils fournis: crochet, spatule et fouet en acier inox - régulateur de vitesse. Accessoires: cuve supplémentaire.

DE Maschine für verschiedene Teigarten wie Pizza, Brot, Kekse, Croissants, Hörnchen, Beignets, Biskuitkuchen, Mürbeteig, Meringuen, Pürees, verschiedene Soßen, Schlagsahne, usw... Gehäuse aus satiniertem Edelstahl -1x5 L Schüssel für SLB5 und 7 L für SLB7 - 3 mitgelieferte Zubehörteile aus Edelstahl: Knethaken, Spachtel und Schneebesen - Geschwindigkeitsregler. Zubehör: Zusatzschüssel.

ES Máquina para varios tipos de masas, como pizza, pan, galletas, croissants, brioches, petisús, bizcocho, merengues, pureas, varias salsas, nata montada, etc. Estructura de acero inoxidable satinado - 1 cuba de 5 L para la SLB5 y de 7 L para la SLB7 - 3 utensilios incluidos, gancho, espátula y batidor todos de acero inoxidable - regulador de velocidad. Accesorios: cuba adicional.

RU Машина для приготовления различных видов теста, например, для пиццы, хлеба, печенья, круассанов, бисквита, песочного теста, безе, пюре, различных соусов, взбитых сливок и т.д. Корпус из матовой нержавеющей стали -1x5 L Чаша для SLB5 и 7 L для SLB7 - 3 принадлежностей из нержавеющей стали: тестовый крючок, лопатка и виск - регулятор скорости. Аксессуары: дополнительная дежа для теста.

	ABX-SLB5	ABX-SLB7
	0,5 kW	0,5 kW
	220-240V/1N/50-60 Hz	
	0 - 302 rpm	0 - 302 rpm
	5 L	7 L
	380 x 240 x 350/500(h) mm	380 x 240 x 400/550(h) mm
		
	13 Kg	15 Kg
	14 Kg	17 Kg
	450 x 330 x 460(h) mm	450 x 330 x 490(h) mm
	0,069 m³	0,075 m³
		
	520 €	590 €

	V5VA	V7VA
	Vasca - Bowl - Cuve - Wanne - Depósito - Чаша объемом	
	5 L	7 L
	63 €	73 €

ABX-B10K
ABX-B20K
ABX-B30K



Planetarie 3 velocità
trasmissione ad ingranaggi



IT Macchine per diversi tipi di impasto, quali pizza, pane, biscotti, croissant, brioche, bigné, pan di spagna, pasta frolla, meringhe, puree, maionese, salse varie, panna montata, ecc. Struttura rivestita con vernice antigraffio - vasca, frusta e coperchio grigliato in acciaio inox AISI 304 - spirale e spatola in alluminio - microinterruttore su coperchio e vasca - vasca estraibile - innesto rapido utensili - cambio meccanico a 3 velocità con trasmissione ad ingranaggi - salvamotore escluso modello B10K. I modelli B10K e B20K sono da banco.















EN Machine for different types of dough such as pizza, bread, biscuits, croissants, brioche, cream puffs, sponge cake, shortcrust pastry, meringues, purees, various sauces, whipped cream, etc.. Casing coated with scratch-proof paint - bowl, whisk and grilled lid in stainless steel AISI 304 - hook and spatula in aluminium - microswitch on bowl and lid - removable bowl - quick tool connection - 3-speed mechanical transmission with gear system - Motor protection excluded model B10K. Models B10K and B20K are counter-top models.

FR Machine pour différents types de pâte tels que pizza, pain, biscuits, croissants, brioche, pains à la crème, gâteau éponge, pâte brisée, meringues, purées, sauces, crème fouettée, etc. Corps recouvert de peinture anti-rayures - cuve, fouet et couvercle grillé en acier inox - crochet et spatule en aluminium - microinterruteur sur la cuve et sur le couvercle - cuve amovible - dégagement rapide des outils - motoréducteur mécanique à 3 vitesses avec engrenage protection du moteur exclu modèle B10K. Les modèles B10K et B20K sont des modèles à poser.

DE Maschine für verschiedene Teigarten wie Pizza, Brot, Kekse, Croissants, Hörnchen, Beignets, Biskuitkuchen, Mürbeteig, Meringues, Pürees, verschiedene Soßen, Schlagsahne, usw... Gehäuse mit kratzfester Lackierung - Teigschüssel, Rührreinsatz und Gitterdeckel aus Edelstahl - Haken und Spachtel aus Aluminium - Mikroschalter an der Wanne und am Deckel - ausziehbare Teigschüssel - Werkzeugschnellkupplung - 3-Gang-Mechanikgetriebe mit Zahnradgetriebe - Motorschutz ausgenommen Modell B10K. Die Modelle B10K und B20K sind Tischmodelle.

ES Máquina para varios tipos de masas, como pizza, pan, galletas, croissants, brioche, petisúes, bizcocho, merengues, pureas, varias salsas, nata montada, etc. Estructura recubierta con pintura anti-arañazos - bol, batidor y tapa de acero inoxidable - gancho y espátula de aluminio - microinterruptor en la protección del bol y en la tapa - bol extraíble - enganche rápido de utensilios - caja de cambios mecánica de 3 velocidades con transmisión por piñón - protección del motor excluido modelo B10K. Los modelos B10K y B20K son modelos de sobremesa.

RU Машина для приготовления различных видов теста, например, для пиццы, хлеба, печенья, круассанов, бисквита, песочного теста, безе, пюре, различных соусов, взбитых сливок и т.д. Корпус покрыт устойчивой к царапинам краской - дежа для теста, мешалка и защита чаши из нержавеющей стали - крючок и лопатка из алюминия - микровыключатель на защите чаши и дежи для теста - извлекаемая дежа для теста - быстроразъемная муфта - защита двигателя за исключением модели B10K. Модели B10K и B20K являются настольными моделями.

	ABX-B10K	ABX-B20K	ABX-B30K
	0,45 kW (0,6 HP)	1,1 kW (1,5 HP)	
	-	400V/3N/50Hz	
	230V/1N/50Hz		-
	113 - 184 - 341 rpm	108 - 161 - 382 rpm	
	NO	0-60'	
	10 L	20 L	30 L
	452 x 432 x 606(h) mm	530 x 496 x 780(h) mm	546 x 512 x 852(h) mm
			
	56 Kg	85 Kg	148 Kg
	69 Kg	104 Kg	179 Kg
	550 x 495 x 720(h) mm	640 x 570 x 880(h) mm	725 x 650 x 1135(h) mm
	0,198 m³	0,322 m³	0,535 m³
			
	1.400 €	1.910 €	3.000 €

Frusta - Whisk - Fouet Rührreinsatz Batidor - Венчик		
B10K	B20K	B30K
ACB10KWP	ACB20KWP	ACB30KWP
42 €	62 €	123 €

Uncino - Hook - Crochet Haken - Gancho - Крюк		
B10K	B20K	B30K
ACB10KHK	ACB20KHK	ACB30KHK
42 €	50 €	76 €

Spatola - Beater - Spatule Schaber - Espátula - Лопатка		
B10K	B20K	B30K
ACB10KBR	ACB20KBR	ACB30KBR
42 €	50 €	76 €

Vasca - Bowl - Cuve Teigschüssel - Cuba - Ёмкость		
B10K	B20K	B30K
ACB10KBL	ACB20KBL	ACB30KBL
69 €	84 €	310 €

ABX-B40K
ABX-B60I



ABX-B40K



ABX-B60I

**Planetarie 3 velocità
trasmissione ad ingranaggi**



- IT** Macchina per diversi tipi di impasto, quali pizza, pane, biscotti, croissant, brioche, bigné, pan di spagna, pasta frolla, meringhe, puree, maionese, salse varie, panna montata, ecc. Struttura rivestita con vernice antigraffio - vasca, frusta e coperchio grigliato in acciaio inox - spirale e spatola in alluminio - microinterruttore su coperchio e vasca - vasca estraibile - innesto rapido utensili - cambio meccanico a 3 velocità con trasmissione ad ingranaggi - salvamotore - carrello estrazione vasca solo su B60I.
- EN** Machine for different types of dough such as pizza, bread, biscuits, croissants, brioches, cream puffs, sponge cake, shortcrust pastry, meringues, purees, various sauces, whipped cream, etc.. Casing coated with scratch-proof paint - bowl, whisk and grilled lid in stainless steel - hook and spatula in aluminium - microswitch on bowl and lid - removable bowl - quick tool connection - 3-speed mechanical transmission with gear system - motor protection - bowl extraction slide only on B60I.
- FR** Machine pour différents types de pâte tels que pizza, pain, biscuits, croissants, brioches, pains à la crème, gâteau éponge, pâte brisée, meringues, purées, sauces, crème fouettée, etc. Corps recouvert de peinture anti-rayures - cuve, fouet et couvercle grillé en acier inox - crochet et spatule en aluminium - microinterruteur sur la cuve et sur le couvercle - cuve amovible - dégagement rapide des outils - motoréducteur mécanique à 3 vitesses avec engrenage - protection du moteur - chariot d'extraction de la cuve uniquement sur B60I.
- DE** Maschine für verschiedene Teigarten wie Pizza, Brot, Kekse, Croissants, Hörnchen, Beignets, Biskuitkuchen, Mürbeteig, Meringues, Pürees, verschiedene Soßen, Schlagsahne, usw... Gehäuse mit kratzfester Lackierung - Teigschüssel, Rührersatz und Gitterdeckel aus Edelstahl - Haken und Spachtel aus Aluminium - Mikroschalter an der Wannen und am Deckel - ausziehbare Teigschüssel - Werkzeugschnellkupplung - 3-Gang-Mechanikgetriebe mit Zahnradgetriebe - Motorschutz - Schüsselauszugsschiene nur bei B60I.
- ES** Máquina para varios tipos de masas, como pizza, pan, galletas, croissants, brioches, petisúes, bizcocho, merengues, pureas, varias salsas, nata montada, etc. Estructura recubierta con pintura anti-arañazos - bol, batidor y tapa de acero inoxidable - gancho y espátula de aluminio - microinterruptor en la protección del bol y en la tapa - bol extraíble - enganche rápido de utensilios - caja de cambios mecánica de 3 velocidades con transmisión por piñón - protección del motor - carro de extracción de cuba sólo en B60I.
- RU** Машина для приготовления различных видов теста, например, для пиццы, хлеба, печенья, круассанов, бисквита, песочного теста, безе, пюре, различных соусов, взбитых сливок и т.д. Корпус покрыт устойчивой к царапинам краской - дежа для теста, мешалка и защита чаши из нержавеющей стали - крючок и лопатка из алюминия - микровыключатель на защите чаши и дежи для теста - извлекаемая дежа для теста - быстроразъемная муфта - 3-ступенчатая механический шестеренчатый редуктор - защита двигателя - тележка отбора мощности только на B60I.

	ABX-B40K	ABX-B60I
	1,3 kW (1,75 HP)	1,5 kW (2 HP)
	400V/3N/50Hz	
	84 - 151 - 270 rpm	74 - 150 - 288 rpm
	0-60'	
	40 L	60 L
	622 x 572 x 970(h) mm	724 x 652 x 1300(h) mm
	151 Kg	231 Kg
	182 Kg	270 Kg
	725 x 650 x 1135(h) mm	850 x 720 x 1395(h) mm
	0,535 m³	0,854 m³
	4.570 €	7.100 €

	ELACB60KCAR	
	420 x 420 x 1020(h) mm	
	12,2 Kg	
	640 x 430 x 610(h) mm	
	290 €	

Frusta - Whisk - Fouet Rührersatz Batidor - Венчик	
B40K	B60I
ACB40KWP	ACB60KWP
231 €	254 €

Uncino - Hook - Crochet Haken - Gancho - Крюк	
B40K	B60I
ACB40KHK	ACB60IHK
240 €	262 €

Spatola - Beater - Spatule Schaber - Espátula - Лопатка	
B40K	B60I
ACB40IBR	ACB60IBR
126 €	137 €

Vasca - Bowl - Cuve Teigschüssel - Cuba - Ёмкость	
B40K	B60I
ACB40IBL	ACB60IBL
368 €	405 €

ABX-K5

ABX-K7P

ORIGINAL
BRAND



ABX-K5



ABX-K7P

KitchenAid®

**Impastatrice planetaria
kitchenaid**



IT K5: Struttura rivestita con vernice antigraffio bianca - 1 vasca inox da 4,83 L - numero 3 utensili in dotazione, uncino, spatola e frusta - 1 presa di forza per accessori - variatore elettronico da 60 a 265 rpm (da 0 a 10).
K7P: Struttura rivestita con vernice antigraffio bianca - 1 vasca inox da 6,9 L - 3 utensili in dotazione, uncino, spatola e frusta lavabili in lavastoviglie - 1 presa di forza per accessori - griglia di protezione vasca - pulsante arresto di emergenza - variatore elettronico da 40 a 200 rpm (da 0 a 10).













EN K5: Structure coated with scratch-proof paint - 4.83 litre stainless steel bowl - delivered with 3 tools - hook, spatula and whip - 1 universal accessories connection.
K7P: Structure coated with white scratch-proof paint - 6.9 litre stainless steel bowl - delivered with 3 tools: hook, spatula and whip dishwasher safe - 1 universal accessories connection - bowl protection grid - emergency stop button - electronic gearbox from 40 to 200 rpm (0 to 10).

FR K5: Corps recouvert de peinture anti-rayures - 1 cuve inox de 4,38 litres - 3 outils de série: crochet, spatule e fouet - 1 serrage pour accessoires - variateur électronique de vitesse de 60 à 265 tr/min (0 à 10).
K7P: Corps recouvert de peinture anti-rayures - 1 cuve inox de 6,9 litres - 3 outils de série: crochet, spatule e fouet - 1 serrage pour accessoires - grille de protection cuve - interrupteur d'arrêt d'urgence - variateur électronique de vitesse de 40 à 200 tr/min (0 à 10).

DE K5: Gehäuse mit weißer kratzfester Lackierung überzogen. 1 Edelstahlschüssel mit 4,83 L Kapazität - 3 beiliegende Werkzeuge, Haken, Spachtel und Rührreinsatz - 1 Außenantrieb für Zubehörteile.
K7P: Gehäuse mit weißer kratzfester Lackierung überzogen. 1 Edelstahlschüssel mit 6,9 L Kapazität - 3 beiliegende Werkzeuge, Haken, Spachtel und Rührreinsatz - 1 Außenantrieb für Zubehörteile Schutzgitter - Notaus Schalter - elektronischer Frequenzumrichter von 40 bis 200 U/min (0 bis 10).

ES K5: Estructura recubierta con pintura anti-arañazos blanca - 1 bol de acero inoxidable de 4,83 litros - 3 utensilios en la dotación, gancho, espátula y batidor - 1 toma de fuerza para los accesorios - variador electrónico de 60 a 265 rpm (de 0 a 10).
K7P: recubierta con pintura anti-arañazos blanca - 1 bol inoxidable de 6,9 L - 3 utensilios en la dotación, gancho, espátula, batidor que se puede limpiar en lavavajillas - 1 toma de fuerza para los accesorios - red de protección del bol - botón de parada de emergencia - variador electrónico de 40 a 200 rpm (de 0 a 10).

RU K5: Корпус покрыт белой устойчивой к царапинам краской. 1 дежа из нержавеющей стали объемом 4,83 л. - 3 прилагаемых инструмента, крючок, лопатка и мешалка - 1 внешний привод для принадлежностей.
K7P: Корпус покрыт белой устойчивой к царапинам краской. 1 дежа из нержавеющей стали объемом 4,83 л. - 3 прилагаемых инструмента, крючок, лопатка и мешалка - 1 внешний привод для принадлежностей Защитная решетка - аварийный выключатель - электронный преобразователь частоты от 40 до 200 об / мин (от 0 до 10).

	ABX-K5	ABX-K7P
	0,315 kW	0,325 kW
 1 Ph	230V/1N/50-60Hz	
	4,83 L	6,9 L
	390 x 290 x 420(h) mm	340 x 370 x 420(h) mm
		
 NET Kg	12,5 Kg	13 Kg
 GROSS Kg	14 Kg	14,8 Kg
 mm	390 x 320 x 500(h) mm	430 x 340 x 490(h) mm
 m ³	0,063 m ³	0,071 m ³
		
	1.087 €	1.695 €

OPTIONAL





Optional impastatrici kitchenaid

	Frusta - Whisk Fouet - Rührreinsatz Batidor - Венчик	Uncino - Hook Crochet - Haken Gancho - Крюк	Spatola - Beater Spatule - Schaber Espátula - Лопатка	Vasca - Bowl Cuve - Teigschüssel Cuba - Ёмкость
Mod.	ABX-K7EW	ABX-K7SDH	ABX-K7SFB	ABX-K7SB
				
	108 €	187 €	238 €	187 €

	Frusta - Whisk Fouet - Rührreinsatz Batidor - Венчик	Uncino - Hook Crochet - Haken Gancho - Крюк	Spatola - Beater Spatule - Schaber Espátula - Лопатка	Vasca - Bowl Cuve - Teigschüssel Cuba - Ёмкость	Estrattore succhi - Juice extractor Extracteur de jus - Entsafter Extractor de jugo - Соковыжималка
Mod. ABX-K5	ABX-K5AWW	ABX-K5ADH	ABX-K5AB	ABX-K5ASB	ABX-5KSM1JA
					
	85 €	63 €	63 €	164 €	340 €

	Tritacarne Grinder Hache-viande Fleischwolf Picadora de carne Мясорубка	Passa verdura/frutta (utilizzabile solo con FGA) Vegetable/fruit stainer (works only with FGA) Passe-légumes/fruits (utilisable uniquement avec FGA) Gemüse/Obstpassiereinheit (nur mit FGA verwendbar) Pasa verduras/fruta (a usar solo con FGA) Насадка для протирки овощей/фруктов (применяемая только с FGA)
Mod. ABX-K5-K7P	ABX-FGA	ABX-FVSP
		
	180 €	180 €

	Sfogliatrice+2 tagliasfoglia 1,5 - 6,5 mm Pasta roller with 2 pasta cutters 1,5 - 6,5 mm Laminoir + 2 roulettes à pâte 1,5 - 6,5 mm Einheit zum Ausrollen von Teig + 2 Teigschneider 1,5 - 6,5 mm Amasadora de pasta + 2 cortadoras de pasta de 1,5 - 6,5 mm Машинка для раскатки теста + 2 прибора для нарезки тонких слоёв теста	Raviolatrice Ravioli maker Raviolatrice Einheit für Ravioli Máquina para raviolis Машинка для приготовления ravioli
Mod. ABX-K5-K7P	ABX-KPRA	ABX-KRAV
		
	334 €	300 €

ABX-FD21
ABX-FD47
ABX-FD66



ABX-FD21



ABX-FD47



ABX-FD66

Forni a convezione



- IT** Forni a convezione ventilati - struttura in acciaio inox - termostato meccanico 65÷260°C , timer meccanico 0÷120 minuti - porta con doppio vetro. Griglie incluse.
- EN** Ventilated convection ovens - stainless steel structure - mechanical thermostat 65 ÷ 260°C , mechanical timer 0 ÷ 120 minutes - door with double glass. Grids included.
- FR** Fours à convection ventilés - structure en acier inox - thermostat mécanique 65 ÷ 260°C, minuterie mécanique 0 ÷ 120 minutes - porte avec double vitrage. Grille inclus.
- DE** Umluftkonvektionsöfen - Edelstahlgehäuse - mechanischer Thermostat 65 ÷ 260°C, mechanischer Timer von 0 bis 120 Minuten - Tür mit Doppelglas. Inklusive Rost.
- ES** Hornos de convección ventilados - estructura de acero inoxidable - termostato mecánico 65 ÷ 260°C, temporizador mecánico 0 ÷ 120 minutos - puerta con doble cristal. Rejilla incluidas.
- RU** Вентилируемые конвекционные печи - конструкция из нержавеющей стали - механический термостат 65 ÷ 260°C, механический таймер 0 ÷ 120 минут - дверца с двойным стеклом. Решётка включены.

	ABX-FD21	ABX-FD47	ABX-FD66
	2,1 kW	2,5 kW	2,8 kW
 1 Ph	230V/1N/50-60Hz		
	21 L - 3 x GN1/2 358 x 291 x 219 mm	47 L - 4 x 45x33 cm 470 x 356 x 250 mm	66 L - 4 x 45x33 cm 470 x 356 x 355 mm
	475 x 500 x 380(h) mm	580 x 560 x 400(h) mm	580 x 570 x 510(h) mm
			
 NET Kg	15 Kg	20 Kg	24 Kg
 GROSS Kg	18 Kg	24 Kg	27 Kg
 mm	570 x 570 x 460(h) mm	650 x 650 x 470(h) mm	660 x 650 x 580(h) mm
 m ³	0,149 m ³	0,199 m ³	0,250 m ³
			
	530 €	840 €	950 €

ABX-P90DZH

ABX-M25LZS



ABX-P90DZH

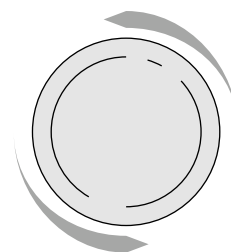

PIATTO GIREVOLE



ABX-M25LZS

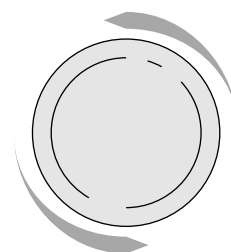

PIATTO GIREVOLE

Forni microonde



IT P90DZH: Forno a microonde con comandi digitali e piatto girevole. Lamiera verniciata nera con porta vetro a specchio - 6 livelli di potenza - funzione defrost - timer digitale - segnale di allarme di fine cottura - controllo di sicurezza per bambini - potenza resa 0,9 kW.

M25LZS: Forno a microonde con comandi meccanici e piatto girevole.

Lamiera verniciata bianca con porta vetro - 6 livelli di potenza - funzione defrost - potenza resa 0,9 kW.

EN P90DZH: Microwave oven with digital controls and rotating plate. Black painted plate with mirrored glass door - 6 power levels - defrost function - digital timer - warning signal at the end of cooking - child safety control - power output 0,9 kW. M25LZS: Microwave oven with mechanical controls and rotating plate.

White painted plate with glass door - 6 power levels - defrost function - Power output 0,9 kW.

FR P90DZH: Four à micro-ondes à commande numérique et plan tournant. Tôle peinte en noir avec porte réfléchissante - 6 niveaux de puissance - fonction dégivrage - minuterie numérique - alarme de fin de cuisson - contrôle de sécurité pour enfants - puissance de 0,9 kW.

M25LZS: Four à micro-ondes avec commandes mécaniques et plan tournant.

Tôle peinte en blanc avec porte vitrée - 6 niveaux de puissance - fonction dégivrage - puissance de 0,9 kW.













DE P90DZH: Mikrowelle mit digitaler Steuerung und drehendem Teller. Schwarz lackiertes Blech mit Spiegelglastür - 6 Leistungsstufen - Abtaufunktion - Digitaltimer - Kochende Warnsignal - Kindersicherung Innenbeleuchtung - Leistung 0,9 kW.

M25LZS: Mikrowelle mit mechanischer Steuerung und drehendem Teller. Weiß lackiertes Blech mit Glastür - 6 Leistungsstufen - Abtaufunktion - Innenbeleuchtung - Leistung 0,9 kW.

ES P90DZH: Chapa pintada de color negro con puerta de cristal espejo - 6 niveles de potencia - función de descongelación - temporizador digital - señal de alarma de fin de cocción - control de seguridad para niños - potencia de salida 0,9 kW. M25LZS: Microondas con mandos mecánicos y plataforma giratoria. Chapa pintada de blanco con puerta de cristal - 6 niveles de potencia - función de descongelación - potencia de salida 0,9 kW.

RU P90DZH: Микроволновая печь с цифровым управлением и поворотным стол. Окрашенный в черный цвет листовой металл с зеркальной стеклянной дверцей - 6 уровней мощности - функция размораживания - цифровой таймер - сигнал тревоги в конце приготовления - контроль безопасности для детей выход мощности 0,9 кВт.-

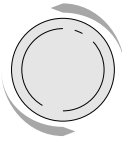
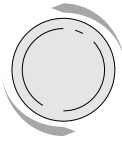
M25LZS: Микроволновая печь с механическим управлением и поворотным столом. Окрашенный в белый цвет листовой металл со стеклянной дверцей - 6 уровней мощности - функция размораживания - выход мощности 0,9 кВт.

	ABX-P90DZH	ABX-M25LZS
	0,9 kW	
	230-240V/1N/50Hz	
	25 L	
	480 x 380 x 281(h) mm	480 x 380 x 275 (h) mm
		
	14 Kg	15 Kg
	14,5 Kg	16 Kg
	547 x 456 x 337(h) mm	
	0,084 m³	
	 Ø 270 mm	 Ø 270 mm
		
	250 €	200 €

ABX-MC1800

ABX-ME1630

FUORI PRODUZIONE - OUT OF PRODUCTION



ABX-MC1800

Forni microonde



IT MC1800: Forno microonde professionale con comandi digitali - display a led - camera di cottura, rivestimento interno e maniglia in acciaio inox - fondo camera in vetroceramica termoresistente - 2 magnetron Toshiba con antenne contrapposte - distribuzione microonde dall'alto verso il basso - piano intermedio in vetro temperato - 5 livelli di potenza - 10 tasti programmabili - filtro aria removibile - segnale acustico fine ciclo - illuminazione interna - potenza resa 1,8 kW.

EN MC1800: Professional microwave oven with digital controls - LED display - cooking chamber, internal lining and handle in stainless steel - chamber bottom in thermoresistant ceramic glass - 2 Toshiba magnetron with opposite antennas - microwave distribution from top to bottom - tempered glass intermediate shelf - 5 power levels - 10 programmable keys - removable air filter - acoustic signal at the end of the cycle - internal lighting - power output 1.8 kW.

FR MC1800: Four à micro-ondes professionnel à commande numérique - Affichage à LED - Chambre de cuisson, revêtement intérieur et poignée en acier inox - fond de la chambre en vitrocéramique réfractaire - 2 magnétrons Toshiba avec antennes opposées - distribution micro-ondes de haut en bas - étagères intermédiaires en verre trempé - 5 puissances - 10 touches programmables - filtre à air amovible - signal acoustique à la fin du cycle - éclairage interne - puissance de 1,8 kW.

DE MC1800: Professioneller Mikrowellenofen mit digitaler Steuerung - LED-Anzeige - Garraum, Innenverkleidung und Griff aus Edelstahl - untere Kammer aus hitzebeständiger Glaskeramik - 2 Toshiba-Magnetrons mit gegenüberliegenden Antennen - Mikrowellenverteilung von oben nach unten - Zwischenboden aus gehärtetem Glas - 5 Leistungsstufen - 10 programmierbare Tasten - abnehmbarer Luftfilter - akustisches Signal am Ende des Zyklus - Innenbeleuchtung - Leistung 1,8 kW.

ES MC1800: Microondas profesionales con mandos digitales - pantalla LED - cámara de cocción, revestimiento interior y mango de acero inoxidable - cámara inferior de vitrocerámica resistente al calor - 2 magnetrones Toshiba con antenas opuestas - distribución de microondas de arriba abajo - nivel intermedio de cristal templado - 5 niveles de potencia - 10 teclas programables - filtro de aire extraíble - señal acústica al final del ciclo - iluminación interior - potencia de salida 1,8 kW.

RU MC1800: Профессиональная микроволновая печь с цифровым управлением - LED дисплей - камера, внутренняя подкладка и ручка из нержавеющей стали - нижняя камера из жаропрочного стеклокерамики - 2 магнита Toshiba с противоположными антеннами - распределение мощности от верхней до нижней - промежуточная полка из закаленного стекла - 5 уровней мощности - 10 программируемых клавиш - съемный воздушный фильтр - акустический сигнал в конце цикла - внутреннее освещение - выход мощности 1,8 кВт.

	MC1800
	3 kW
	230V/1N/50Hz
	Digitale - Digital - Цифровой 0÷60'
	35 L - GN2/3 360 x 400 x 228(h) mm
	570 x 512 x 370(h) mm
	30,5 Kg
	32,5 Kg
	641 x 559 x 451(h) mm
	0,148 m ³
	1.935 €

ABX-MF914

ABX-MC2452



ABX-MF914

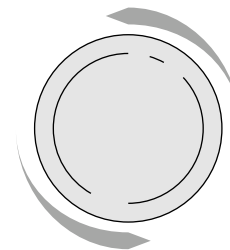

PIATTO GIREVOLE

Forni microonde



- IT** MF914: Forno a microonde con grill - comandi digitali - camera di cottura e rivestimento esterno in acciaio inox - 1 magnetron - 5 livelli di potenza in modalità microonde, 2 in modalità combinata, 1 in modalità grill - 8 modalità di cottura preimpostate - funzione defrost - illuminazione interna - potenza resa 0,9 kW. MC2452: Forno microonde con convezione, grill e comandi digitali - camera di cottura e rivestimento esterno in acciaio inox - 1 magnetron - funzionamento combinato, C-1 microonde + convezione; C-2 microonde +grill; C-3 grill + convezione; C-4 microonde + convezione + grill; illuminazione interna - potenza resa 0,9 kW microonde, 2,4 kW per modalità convezione ed infine 1,4 kW in grill.
- EN** MF914: Microwave oven with grill - digital controls - stainless steel cooking chamber and external casing - 1 magnetron - 5 power levels in microwave mode, 2 in combined mode, 1 in grill mode - 8 preset cooking modes - defrost function - internal lighting - power output 0,9 kW. MC2452: Microwave oven with convection, grill and digital controls - stainless steel cooking chamber and external coating - 1 magnetron - combined operation, C-1 microwave + convection; C-2 microwave + grill; C-3 grill + convection; C-4 microwave + convection + grill; internal lighting - power output 0.9 kW microwave, 2.4 kW for convection mode and 1.4 kW in grill.
- FR** MF914: Four à micro-ondes avec grill - commandes numériques - chambre de cuisson et revêtement extérieur en acier inox - 1 magnétron - 5 niveaux de puissance en modalité micro-ondes, 2 en modalité combinée, 1 en modalité grille - 8 types de cuisson prédéfinis - fonction décongélation - éclairage interne - puissance 0,9 kW MC2452: Four à micro-ondes avec convection, grill et commandes numériques - chambre de cuisson et revêtement extérieur en acier inox - 1 magnétron - fonctionnement combiné, micro-ondes C-1 + convection; C-2 micro-ondes + grille; C-3 grill + convection; C-4 micro-ondes + convection + grill; éclairage interne - puissance 0,9 kW micro-ondes, 2,4 kW pour mode convection et 1,4 kW en grille
- DE** MF914: Mikrowellenherd mit Grill - digitale Steuerung - Edelstahl-Garraum und Außenverkleidung - 1 Magnetron - 5 Leistungsstufen im Mikrowellenmodus, 2 im Kombi-Modus, 1 im Grillmodus - 8 voreingestellte Gararten - Abtaufunktion - Innenbeleuchtung - Leistung 0,9 kW MC2452: Mikrowelle mit Konvektions-, Grillfunktion und Digitalsteuerung - Garraum und Außenbeschichtung aus Edelstahl - 1 Magnetron - Kombi-Betrieb, C-1 Mikrowelle + Konvektion; C-2 Mikrowelle + Grill; C-3 Grill + Konvektion; C-4 Mikrowelle + Konvektion + Grill; Innenbeleuchtung - Stromabgabe 0,9 kW Mikrowelle, 2,4 kW für Konvektionsmodus und schließlich 1,4 kW im Grill.
- ES** MF914: Microondas con gratinadora - mandos digitales - cámara de cocción y revestimiento exterior de acero inoxidable - 1 magnetron - 5 niveles de potencia en modo microondas, 2 en modo combinado, 1 en modo grill - 8 modos de cocción preajustados - función de descongelamiento - iluminación interna - potencia de 0,9 kW. MC2452: Microondas con convección, parrilla y mandos digitales - cámara de cocción y revestimiento exterior de acero inoxidable - 1 magnetron - funcionamiento combinado, C-1 microondas + convección; C-2 microondas + parrilla; C-3 parrilla + convección; C-4 microondas + convección + parrilla; iluminación interna - potencia 0,9 kW microondas, 2,4kW convección y 1,4kW en parrilla.
- RU** MF914: Микроволновая печь с грилем - цифровое управление - камера нагрева из нержавеющей стали и наружная облицовка - 1 магнит - 5 уровней мощности в режиме микроволновой печи, 2 в комбинированном режиме, 1 в режиме гриля - 8 предустановленных режимов - функция оттайки - внутреннее освещение - выходная мощность 0,9 кВт MC2452: Микроволновая печь с функциями конвекции, гриля и цифровым управлением - варочная камера с наружным покрытием из нержавеющей стали - 1 магнетрон - комбинированный режим, C-1 микроволновая печь + конвекция; C-2 микроволновая печь + гриль; C-3 гриль + конвекция; C-4 микроволновая печь + конвекция + гриль; внутреннее освещение - мощность 0,9 кВт, 2,4 кВт в режиме конвекции и 1,4 кВт в гриля.

	ABX-MF914	ABX-MC2452
	1,45 kW	2,4 kW
	230V/1N/50Hz	
	Digitale - Digital - Цифровой 0÷95'	
	25 L 330 x 350 x 200(h) mm	25 L 328 x 343 x 230(h) mm
	513 x 400 x 305 (h) mm	510 x 466 x 305(h) mm
	16 Kg	18 Kg
	17,5 Kg	20 Kg
	580 x 460 x 350(h) mm	580 x 495 x 363(h) mm
	0,094 m³	0,104 m³
	Ø 300 mm	MULTIFUNCTION
	390 €	410 €

ABX-MJ6051AT
ABX-MJ6091AT

NUOVI
MODELLI
NEW
MODELS



ABX-MJ6051AT

SAMSUNG

ORIGINAL
BRAND

Forni a microonde
Samsung



IT Forni a microne Samsung. Struttura e camera di cottura in acciaio inox - 2 magnetron - 5 livelli di potenza - comandi manuali - camera di cottura da 26 L con fondo fisso - illuminazione interna - filtro aria facilmente removibile - sovrapponibile.













EN Samsung microwave ovens. Stainless steel casing and cooking chamber - 2 magnetrons - 5 power levels - manual controls - 26 L cooking chamber with fixed bottom - internal lighting - easily removable air filter - stackable.

FR Fours à micro-ondes Samsung. Corps et chambre de cuisson en acier inox - 2 magnétons - 5 niveaux de puissance - commandes manuelles - chambre de cuisson 26 lt. à fond fixe - éclairage interne - filtre à air facilement amovible - superposable.

DE Samsung Mikrowellenöfen. Gehäuse und Garkammer aus Edelstahl - 2 Magnetrons - 5 Leistungsstufen - manuelle Steuerung - 26 L Garraum mit festem Boden - Innenbeleuchtung - leicht abnehmbarer Luftfilter - stapelbar.

ES Hornos microondas Samsung. Estructura y cámara de cocción de acero inoxidable - 2 magnetrones - 5 niveles de potencia - mandos manuales - cámara de cocción de 26 litros con fondo fijado - iluminación interior - filtro de aire (que se extrae y superpone fácilmente).

RU СВЧ-печи Samsung. Корпус из нержавеющей стали и варочная камера - 2 магнетрона - 5 уровней мощности - ручное управление - 26 литров варочной камеры с фиксированным дном - внутреннее освещение - легкоъемный воздушный фильтр - штабелируемый.

	ABX-MJ6051AT	ABX-MJ6091AT
	1,5 kW	1,85 kW
 1 Ph	230V/1N/50Hz	
	Manuale - Manual - Ручным	
	26 L 370 x 370 x 190(h) mm	
	464 x 557 x 368(h) mm	
		
 NET Kg	32 Kg	
 GROSS Kg	34,5 Kg	
 mm	577 x 469 X 375(h) mm	
 m ³	0,101 m ³	
		
	1.880 €	2.200 €

ABX-MJ6053AT
ABX-MJ6093AT

NUOVI
MODELLI
NEW
MODELS



ABX-MJ6053AT

SAMSUNG

ORIGINAL
BRAND

Forni a microonde
Samsung



IT Forni a microonde Samsung - Struttura e camera di cottura in acciaio inox - 2 magnetron - 50 programmi di cottura e funzione di self service - programmabile - funzione moltiplicatore x2 - contatore cicli lavorativi per programma - blocco tasti - funzione avviso pulizia filtro - camera di cottura da 26 L con fondo fisso - illuminazione interna - filtro aria facilmente removibile - sovrapponibile.













EN Samsung microwave ovens. Stainless steel casing and cooking chamber - 2 magnetrons - 50 cooking programs and self service function - programmable - 2x multiplying function - work cycle counter per program - key lock - filter cleaning warning function - 26 lt. cooking chamber with fixed bottom - internal lighting - easily removable air filter - stackable.

FR Four à micro-ondes Samsung - Corps et chambre de cuisson en acier inox - 2 magnétron - 50 programmes de cuisson et fonction self-service - programmable - fonction multiplicateur x2 - compteur de cycles de travail pour chaque programme - verrouillage du clavier - fonction avertisseur de nettoyage du filtre - chambre de cuisson 26 lt. avec fond fixe - éclairage interne - filtre à air facilement amovible - superposable.

DE Samsung Mikrowellenöfen. Gehäuse und Garkammer aus Edelstahl - 2 Magnetrons - 50 Garprogramme und Selbstbedienungsfunktion - einstellbar - Multiplikatorfunktion x2 - Arbeitszykluszähler pro Programm - Tastensperre - Filterreinigung Warnfunktion - 26 L Garraum mit festem Boden - Innenbeleuchtung - leicht abnehmbarer Luftfilter - stapelbar.

ES Hornos microondas Samsung. Estructura y cámara de cocción de acero inoxidable - 2 magnetrones - 50 programas de cocción self-service - programable - función de multiplicación X2 - contador de ciclos de trabajo para programa - bloqueo de teclado - alarma que avisa cuando se necesita limpiar el filtro - cámara de cocción de 26 litros con fondo fijado - iluminación interior - filtro de aire (que se extrae y superpone fácilmente).

RU СВЧ-печи Samsung. Корпус из нержавеющей стали и варочная камера - 2 магнетрона - 50 программ приготовления пищи и функция самообслуживания - программируемая - 2 умножающаяся функция - счетчик рабочих циклов по программе - замок клавиш - функция предупреждения о необходимости очистки фильтра - 26 л. камера с фиксированным дном - внутреннее освещение - легкоъемный воздушный фильтр - штабелируемый.

	ABX-MJ6053AT	ABX-MJ6093AT
		
	1,5 kW	1,850 kW
	230V/1N/50Hz	
	Digitale - Digital - Цифровой	
	26 L 370 x 370 x 190(h) mm	
	464 x 557 x 368(h) mm	
		
	32 Kg	
	34,5 Kg	
	577 x 469 x 375(h) mm	
	0,101 m³	
		
	1.880 €	2.200 €

ABX-PANE1840

ABX-PANE3240

















ABX-PANE1840

Forni a microonde Panasonic

Panasonic®



- IT** Forni a microonde Panasonic. Struttura esterna in acciaio inox - 4 magnetron - camera di cottura da 44 L in grado di contenere una vaschetta GN1/1 - fondo fisso in vetro ceramicato - illuminazione interna - ripiano intermedio estraibile in vetro ceramicato. Potenza resa 1,8 kW (PANE1840) - 3,20 kW (PANE3240).
- EN** Panasonic microwave ovens. External casing in stainless steel - 4 magnetrons - 44 L cooking chamber suitable for a GN1/1 tray - fixed bottom in ceramic glass - internal lighting - removable intermediate shelf in ceramic glass. Power yield 1,8 kW (PANE1840) - 3,20 kW (PANE3240).
- FR** Fours à micro-ondes Panasonic. Corps extérieure en acier inox - 4 magnétrons - Chambre de cuisson de 44 L pour bac GN1/1 - fond fixe en verre céramique - éclairage intérieur - tablette intermédiaire amovible en verre céramique. Puissance fournie 1,8 kW (PANE1840) - 3,20 kW (PANE3240).
- DE** Panasonic Mikrowellenöfen. Äußere Gehäuse aus Edelstahl - 4 Magnetrons - 44 L Garraum zur Aufnahme einer GN1/1 Kochplatte - fester Boden aus Keramikglas - Innenbeleuchtung - abnehmbarer Zwischenboden aus Keramikglas. Erzielte Leistung 1,8 kW (PANE1840) - 3,20 kW (PANE3240).
- ES** Hornos microondas Panasonic. Estructura exterior de acero inoxidable - 4 magnetrones - cámara de cocción de 44 litros donde se puede colocar una bandeja GN1/1 - fondo fijado de vidrio hecho de cerámica - iluminación interior - estante intermedio extraíble de vidrio hecho de cerámica. Rendimiento de potencia 1,8 kW (PANE1840) - 3,20 kW (PANE3240).
- RU** Панасонические микроволновые печи. Внешний корпус из нержавеющей стали - 4 магнетрона - 44 л. Камера подходит для противня GN1/1 - фиксированное дно из стеклокерамики - внутреннее освещение - съемная промежуточная полка из стеклокерамики. МОЩНОСТЬ НА ВЫХОДЕ 1,8 kW (PANE1840) - 3,20 kW (PANE3240).

	ABX-PANE1840	ABX-PANE3240
	3 kW	5 kW
	-	400V/3N/50Hz
	230V/1N/50Hz	-
	Digitale - Digital Цифровой 0÷60'	
	44 L 1 x GN 1/1 - 535 x 330 x 250(h) mm	
	650 x 526 x 471(h) mm	
		
	54 Kg	65 Kg
	65 Kg	73 Kg
	760 x 670 x 680(h) mm	
	0,346 m ³	
		
	6.610 €	8.565 €

ABX-FY4L

ABX-FY44L



ABX-FY44L



ABX-FY4L

Friggitrici



IT Friggitrici da 4 L. Modelli da banco. Struttura, vasca e coperchio in acciaio inox - cestelli a rete estraibili in filo cromato - manici cestelli e pomelli coperchi in plastica termoisolante - resistenze inox - termostato di sicurezza con pulsante di ripristino - versioni a due vasche con doppio termostato per utilizzo indipendente - testata e resistenze removibili. Raggiungono i 180°C in circa 18 minuti - tempo di frittura in circa 7 minuti.

EN Fryers capacity 4 L. Table-top models. Casing, bowl and lid in stainless steel - removable baskets in chrome-plated wire - baskets handles and lids knobs in thermo-insulating material - stainless steel resistances - safety thermostat with reset button - two-bowls versions with double thermostat for independent use - header and removable resistances. They reach 180°C in about 18 minutes frying time about 7 minutes.

FR Friteuses capacité 4 L modèles de table. Corps, cuve et couvercle en acier inox - paniers amovibles en fil chromé - poignées et pommeaux des paniers en matériau thermo-isolant - résistance en acier inox - thermostat de sécurité avec bouton de remise à zéro - versions à deux cuves avec double thermostat pour une utilisation indépendante - collecteur et résistances amovibles. Ils atteignent 180°C en environ 18 minutes temps de friture de 7 minutes environ.

DE Friteusen Kapazität 4 L Tischmodelle. Gehäuse, Wanne und Deckel aus Edelstahl - abnehmbare Körbe aus verchromtem Draht - Korbgriffe und Deckelknöpfe aus wärmeisolierendem Material - Heizkörper aus Edelstahl - Sicherheitsthermostat mit Rückstellknopf - Zwei-Wanne-Versionen mit Doppelthermostat für den unabhängigen Gebrauch - Kopfteil und abnehmbare Heizkörper. Sie erreichen 180°C in etwa 18 Minuten Frittierzeit von etwa 7 Minuten.

ES Freidoras de 4 L. Modelos de sobremesa. Carcasa, cuba y tapa de acero inoxidable - cestas desmontables de alambre cromado - asas de cestas y tapas de material termoaislante - resistencias de acero inoxidable - termostato de seguridad con pulsador de rearme - versiones de dos cubas con doble termostato de uso independiente - cabezal y resistencias desmontables. Alcanzan los 180°C en unos 18 minutos de fritura en unos 7 minutos.

RU 4 л фритюрницы. Настольные модели. Корпус, чаша и крышка из нержавеющей стали - съемные корзины из хромированной проволоки - ручки корзин и крышек из термоизоляционного материала - резисторы из нержавеющей стали - предохранительные термостаты. с кнопкой сброса - версии с двумя барабанами и независимым двойным термостатом - головой и съемными нагревательными элементами. Они достигают 180°C примерно за 18 минут времени обжарки примерно за 7 минут.

	ABX-FY4L	ABX-FY44L
	2 kW	2 + 2 kW
	220-240V/1N/50-60Hz	
	50÷200°C	
	7,6 L	7,6 + 7,6 L
	4,2 L	4,2 + 4,2 L
	200 x 140 x 120(h) mm	200 x 140 x 120(h) mm x 2
	210 x 375 x 310(h) mm	435 x 375 x 310(h) mm
	4,5 Kg	8.5 Kg
	5 Kg	10 Kg
	435 x 265 x 340(h) mm	500 x 435 x 340(h) mm
	0,039 m³	0,073 m³
	180 €	350 €



ABX-FY8L

ABX-FY88L



ABX-FY88L



ABX-FY8L

Friggitrici



IT Friggitrici da 8 L. Modelli da banco. Struttura, vasca e coperchio in acciaio inox - cestelli a rete estraibili in filo cromato - manici cestelli e pomelli coperchi in plastica termoisolante - resistenze inox - termostato di sicurezza con pulsante di ripristino - versioni a due vasche con doppio termostato per utilizzo indipendente - testata e resistenze removibili. Raggiungono i 180°C in circa 18 minuti - tempo di frittura in circa 7 minuti.

EN Fryers capacity 8 L. Table-top models. Casing, bowl and lid in stainless steel - removable baskets in chrome-plated wire - baskets handles and lids knobs in thermo-insulating material - stainless steel resistances - safety thermostat with reset button - two-bowls versions with double thermostat for independent use - header and removable resistances. They reach 180°C in about 18 minutes frying time about 7 minutes.

FR Friteuses capacité 8 L modèles de table. Corps, cuve et couvercle en acier inox - paniers amovibles en fil chromé - poignées et pommeaux des paniers en matériau thermo-isolant - résistance en acier inox - thermostat de sécurité avec bouton de remise à zéro - versions à deux cuves avec double thermostat pour une utilisation indépendante - collecteur et résistances amovibles. Ils atteignent 180°C en environ 18 minutes temps de friture de 7 minutes environ.

DE Friteusen Kapazität 8 L Tischmodelle. Gehäuse, Wanne und Deckel aus Edelstahl - abnehmbare Körbe aus verchromtem Draht - Korbgriffe und Deckelknöpfe aus wärmeisolierendem Material - Hetzkörper aus Edelstahl - Sicherheitsthermostat mit Rückstellknopf - Zwei-Wanne-Versionen mit Doppelthermostat für den unabhängigen Gebrauch - Kopfteil und abnehmbare Hetzkörper. Sie erreichen 180°C in etwa 18 Minuten Frittierzeit von etwa 7 Minuten.

ES Freidoras de 8 L. Modelos de sobremesa. Carcasa, cuba y tapa de acero inoxidable - cestas desmontables de alambre cromado - asas de cestas y tapas de material termoaislante - resistencias de acero inoxidable - termostato de seguridad con pulsador de rearme - versiones de dos cubas con doble termostato de uso independiente - cabezal y resistencias desmontables. Alcanzan los 180°C en unos 18 minutos de fritura en unos 7 minutos.

RU 8 л фритюрницы. Настольные модели. Корпус, чаша и крышка из нержавеющей стали - съемные корзины из хромированной проволоки - ручки корзин и крышек из термоизоляционного материала - резисторы из нержавеющей стали - предохранительные термостаты. с кнопкой сброса - версии с двумя барабанами и независимым двойным термостатом - головой и съемными нагревательными элементами. Они достигают 180°C примерно за 18 минут времени обжарки примерно за 7 минут.

	ABX-FY8L	ABX-FY88L
	2,85 kW	2,85 + 2,85 kW
	220-240V/1N/50-60Hz	
	50+200°C	
	12,6 L	12,6 + 12,6 L
	8 L	8 + 8 L
	240 x 185 x 140 (h) mm	240 x 185 x 140 (h) mm x 2
	265 x 410 x 325(h) mm	545 x 410 x 325(h) mm
	6 Kg	11.5 Kg
	8,5 Kg	13 Kg
	450 x 325 x 355(h) mm	580 x 430 x 355(h) mm
	0,051 m³	0,088 m³
	200 €	390 €



ABX-SC8195

ABX-SC82C



ABX-SC8195



ABX-SC82C

Cuocci riso

IT Macchine cuoci riso. Struttura e interno in acciaio inox - in dotazione cucchiaino e misurino da 180 ml.
 Sc8195: Funzione "Cook" per la cottura del riso - funzione "Warm" per il mantenimento della temperatura. Capacità fino a 30 porzioni di riso.
 SD82C: Funzione di scelta per la cottura di diversi tipi di riso "Short Grain Rice" o "Long Grain Rice". Possibilità di cuocere zuppe/porridge e di utilizzare il tasto "Delay Timer" fino ad un massimo di 4 ore. Funzione "Warm" per il mantenimento della temperatura. Capacità fino a 45 porzioni di riso.













EN Rice cookers. Stainless steel casing and interior - supplied with spoon and 180 ml measuring cup.
 C8195: "Cook" function to cook the rice - "Warm" function to maintain the temperature. Capacity up to 30 portions of rice.
 SD82C: Selection function to cook different types of rice "Short Grain Rice" or "Long Grain Rice". Can be used to cook soup/porridge and to use the "Delay Timer" button for up to 4 hours. "Warm" function to maintain the temperature. Capacity up to 45 portions of rice.

FR Machines pour la cuisson du riz. Corps et intérieur en acier inox - livré avec cuillère et cuillère doseuse de 180 ml.
 SC8195: Fonction "Cook" pour la cuisson du riz - Fonction "Warm" pour le maintien en température. Capacité jusqu'à 30 portions de riz.
 SD82C: Fonction de sélection pour la cuisson de différents types de riz "Short Grain Rice" ou "Long Grain Rice". On peut cuire soupe/porridge et la touche "Delay Timer" peut être utilisée jusqu'à 4 heures. Fonction "Warm" pour le maintien en température. Capacité jusqu'à 45 portions de riz.

DE Reiskocher. Gehäuse und Innenbehälter aus Edelstahl - geliefert mit Löffel und 180 ml Messlöffel.
 SC8195: "Cook"-Funktion fürs Reiskochen - "Warm"-Funktion fürs Halten der Temperatur. Bis zu 30 Portionen Reis Kapazität.
 SD82C: Auswahlfunktion für die Zubereitung verschiedener Reissorten "Short Grain Rice" oder Long Grain Rice". Es können Suppe/Brei gekocht werden und die Taste "Delay Timer" kann bis zu 4 Stunden lang verwendet werden. "Warm"-Funktion fürs Halten der Temperatur. Kapazität bis zu 45 Portionen Reis.

ES Máquinas de cocción de arroz. Estructura e interior de acero inoxidable - provisto con cuchara y cuchara dosificadora de 180 ml.
 SC8195: Función "Cook" para cocinar arroz - Función "Warm" para mantener la temperatura. Capacidad hasta 30 porciones de arroz.
 SD82C: Función de selección para cocinar diferentes tipos de arroz "Arroz de grano corto" o "Arroz de grano largo". Se puede cocinar sopa/pastilla y el botón "Delay Timer" se puede utilizar hasta 4 horas. Función "Warm" para mantener la temperatura. Capacidad hasta 45 porciones de arroz.

RU Рисовые плиты. Внутренняя и внутренняя отделка из нержавеющей стали - поставляется с ложкой и 180 мл мерной чашкой.
 SC8195: функция "Готовить" для приготовления риса - функция "Тепло" для поддержания температуры. Вместимость до 30 порций риса.
 SD82C: Функция выбора для приготовления риса различных сортов "Короткозерновой рис" или "Длиннозернистый рис". Используется для приготовления супа/каши и для использования кнопки "Delay Timer" до 4 часов. Функция "Тепло" для поддержания температуры. Вместимость до 45 порций риса.

	ABX-SC8195	ABX-SD82C
		
	1.95 kW	2.5 kW
	230V/1N/50Hz	
	5.4 L (riso crudo - raw rice - сырой рис) 14 L (riso cotto - cooked rice - варёный рис)	8.2 L (riso crudo - raw rice - сырой рис) 22 L (riso cotto - cooked rice - варёный рис)
	480 x 390 x 350/770(h) mm (aperto - open - распахнутый)	540 x 460 x 410/880(h) mm (aperto - open - распахнутый)
		
	9 Kg	14 Kg
	10,5 Kg	16,5 Kg
	455 x 380 x 455(h) mm	540 x 460 x 540(h) mm
	0.078 m ³	0.140 m ³
		
	270 €	460 €













ABX-YKK02A



Cuocì Hot Dog



- IT** Macchina per riscaldare e cuocere panini e würstel. Struttura in acciaio inox - 2 punzoni per riscaldare il pane - termostato - campana in vetro con all'interno cestello inox per cottura würstel a bagno maria.
- EN** Machine for heating and cooking hot dog buns and sausages. Stainless steel casing - 2 buns heating plots - thermostat - glass cylinder with internal stainless steel bowl to heat sausages in a water bath.
- FR** Machine pour le chauffage et la cuisson de petits pains et saucisses. Corps en acier inox - 2 broches pour chauffer le pain - thermostat - cylindre en verre avec bac interne en acier inoxydable pour chauffer les saucisses au bain marie.
- DE** Maschine zum Erwärmen und Kochen von Brötchen und Würstchen. Gehäuse aus Edelstahl - 2 Heizstiften zum Erwärmen des Brotes - Thermostat - Glaszylinder mit innenliegender Edelstahlwanne fürs Heizen von Würsten im Wasserbad.
- ES** Máquina para calentar y cocinar pan y salchichas. Estructura de acero inoxidable - 2 punzones para calentar el pan - termostato - campana de vidrio con cesta interna de acero inoxidable para calentar salchichas en baño maría.
- RU** Прибор для разогревания и приготовления булочек и сосисок. Корпус из нержавеющей стали, 2 штыря для разогревания булочек, термостат, стеклянный колпак, внутри которого помещена корзинка из нержавеющей стали для приготовления сосисок на пару.

	ABX-YKK02A
	0,44 kW
 1 Ph	220-240V/1N/50Hz
	410 x 345 x 315(h) mm
	
 NET Kg	5,7 Kg
 GROSS Kg	6,7 Kg
	415 x 405 x 380(h) mm
	0,063 m³
	
	225 €



ABX-FY011



Cuoci Hot Dog



IT Macchina per riscaldare e cuocere würstel - cottura rapida ed uniforme che conferisce ai prodotti il sapore e la colorazione tipica della cottura alla griglia senza che sia necessario rigirarli manualmente - carcassa in acciaio inox - rulli in acciaio inox AISI304 - doppio termostato per la regolazione della temperatura - 11 rulli di ø 25 mm e lunghezza 467 mm.

EN Hot dog and sausage heating and cooking machine - fast and even cooking that confers products the flavour and colour typical of grilling with no need for manual intervention - stainless steel casing - AISI 304 stainless steel rollers - double thermostat for temperature control - 11 rollers ø 25 mm 467 mm long.

FR Appareil de chauffage et de cuisson pour different saucisses - cuisson rapide et uniforme qui donne aux produits la saveur et la couleur typiques du grillage sans intervention manuelle - corps en acier inox - rouleaux en acier inox AISI 304 - double thermostat pour le contrôle de la température - 11 rouleaux de ø 25 mm et longueur 467 mm.

DE Maschine zum Erwärmen und Garen verschiedener Würstchen - schnelles und gleichmäßiges Garen, um den Produkten den typischen Geschmack und die typische Farbe des Grillens ohne manuelles Eingreifen zu verleihen - Edelstahlgehäuse - Rollen aus Edelstahl AISI 304 - Doppelthermostat zur Temperaturregelung - 11 Rollen mit ø 25 mm und Länge 467 mm.

ES Máquina para calentar y cocinar perritos calientes y salchichas - cocción rápida y uniforme que confiere a los productos el sabor y la coloración típica de la cocción en parrilla sin necesidad de dar la vuelta manualmente - carcasa de acero inoxidable - rodillos de acero inoxidable AISI304 - termostato doble para el control de la temperatura - 11 rodillos de ø 25 mm y longitud 467 mm.

RU Прибор для разогревания и приготовления сосисок и колбасок - Быстрое и равномерное обжаривание, благодаря которому продукты принимают типичный вид приготовленных на гриле без необходимости поворачивать их вручную - Корпус из нержавеющей стали - Валки из нержавеющей стали AISI304 - двойной термостат для регулирования температуры - 11 роликов диаметром 25 мм и длиной 467 мм.

	ABX-FY011
	2,2 kW
 1 Ph	220-240V/1N/50Hz
	ø 25 mm - 467 mm
	560 x 530 x 200(h) mm
 NET Kg	12 Kg
 GROSS Kg	12,5 Kg
 mm	600 x 535 x 220(h) mm
 m³	0,070 m³
	370 €



ABX-HBS220JS

ABX-HBS250

ABX-HBS300



ABX-HBS220JS



ABX-HBS250



ABX-HBS300

Affettatrici a gravità



IT Macchina per affettare salumi, formaggi, ecc. Struttura in lega leggera di alluminio anodizzato - anello fisso protezione lama - paralama estraibile - pomello regolazione vela con scala graduata - affilatoio fisso con coppia di smerigli per l'affilatura della lama. Spessore di taglio per il modello 220JS fino a 12 mm, per il modello 250 fino a 15 mm e per il modello 300 fino a 16 mm - blocco piatto-vela

EN Slicing machine for cold cuts, cheeses, etc. Casing in light anodized aluminium alloy - fixed ring for blade protection - removable blade guard - fence adjustment knob with graduated scale - fixed sharpener with a pair of grinders to sharpen the blade. Cutting thickness for the 220JS model up to 12 mm, for the 250 model up to 15 mm and for the 300 model up to 16 mm - plate block.

FR Trancheuse pour saucisses et fromages, etc. Corps en alliage d'aluminium anodisé léger - anneau fixe pour la protection de la lame - garde lame extractible - bouton de réglage de la voile avec échelle graduée - affûteur fixe avec couple d'émeris pour aiguïser la lame. Epaisseur de coupe pour modèle 220JS jusqu'à 12 mm, pour modèle 250 jusqu'à 15 mm et pour modèle 300 jusqu'à 16 mm - bloc du plan glissant.

DE Schneidemaschine für Wurstwaren, Käse, usw. Gehäuse aus leichter eloxierter Aluminiumlegierung - fester Ring für den Messerschutz - abnehmbarer Messerschutz - Segelverstellknopf mit Skala - fester Schärfer mit einem Paar Schleifer zum Schärfer der Klinge. Schnittdicke für das 220JS Modell bis 12 mm, für das 250 Modell bis 15 mm und für das 300 Modell bis 16 mm - Einführtischsperrle.

ES Máquina para cortar en lonchas embutidos, quesos, etc. Estructura ligera de aleación de aluminio anodizado - anillo fijo para proteger la cuchilla y protección de la cuchilla extraíble - pomo de regulación protección vertical con escala graduada - afilador fijo piedras de amolar para afilar la cuchilla. Espesor del corte hasta 12 mm (modelo 220JS), hasta 15 mm (modelo 250), hasta 16 mm (modelo 300). Bloque plano-protección vertical.

RU Режущая машина для нарезки холодной нарезки, сыров и т.д. Корпус из легкого анодированного алюминиевого сплава - фиксированное кольцо для защиты лезвия - съемная защита лезвия - ручка регулировки ограждения с градуированной шкалой - фиксированная точилка с парой шлифмашин для заточки лезвия. Толщина резания для модели 220JS до 12 мм, для модели 250 до 15 мм и для модели 300 до 16 мм - листовой блок.

	ABX-HBS220JS	ABX-HBS250	ABX-HBS300
	0,12 kW	0,15 kW	0,25 kW
	230V/1N/50Hz		
	220 mm	250 mm	300 mm
	115 x 130(h) mm	140 x 155(h) mm	165 x 175(h) mm
	340 x 240 mm	380 x 250 mm	430 x 300 mm
	490 x 370 x 330(h) mm	520 x 420 x 380(h) mm	560 x 490 x 450(h) mm
	12 Kg	18 Kg	23 Kg
	14 Kg	20 Kg	26 Kg
	520 x 420 x 380(h) mm	575 x 465 x 415(h) mm	615 x 525 x 510(h) mm
	0,083 m³	0,111 m³	0,165 m³
	546 €	680 €	910 €



ABX-HT4-HT5.5



ABX-HT4-HT4











ABX-HT4-HT5.5

Taglia pomodori manuali



- IT** Macchina per tagliare pomodori. Struttura in acciaio inox e plastica alimentare. Il modello HT4 ha uno spessore di taglio di 4mm, mentre il modello HT5.5 ha spessore di 5,5 mm.
- EN** Tomato cutting machine. Stainless steel and food safe plastic casing. The HT4 model has a cutting thickness of 4mm, while the HT5.5 model has a thickness of 5,5 mm.
- FR** Machine à couper les tomates. Corps en acier inox et plastique alimentaire. Le modèle HT4 a une épaisseur de coupe de 4 mm, et le modèle HT5.5 a une épaisseur de 5,5 mm.
- DE** Tomatenschneidemaschine. Gehäuse aus Edelstahl und lebensmittelechtem Kunststoff. Das Modell HT4 hat eine Schnittdicke von 4 mm, während das Modell HT5.5 eine Dicke von 5,5 mm hat.
- ES** Máquina para cortar tomates. Estructura de acero inoxidable y plástico idóneo para el contacto con los alimentos. Espesor del corte: 4 mm (modelo HT4) o 5,5 mm (modelo HT5.5).
- RU** Машина для резки помидоров. Корпус из нержавеющей стали и пищевого безопасного пластика. Модель HT4 имеет толщину пропила 4 мм, а модель HT5.5 - 5,5 мм.

	ABX-HT4	ABX-HT5.5
		
LAME BLADES ЛЕЗВИЙ	N° 13	N° 10
	450 x 200 x 205(h) mm	
		
	5 Kg	
	6 Kg	
	450 x 210 x 210(h) mm	
	0,020 m³	
		
	210 €	205 €



ABX-SS7H-SL12H



SL12H
ABX-SS7H-SL12H



ABX-SS7H-SS7H

Insaiatrici manuali orizzontali



IT Macchina per insaccare. Struttura in acciaio inox - 2 velocità - in dotazione 4 imbuti (10-20-30-35 mm).





EN Sausage stuffer machine. Stainless steel casing - 2 speeds - supplied with 4 funnels (10-20-30-35 mm).

FR Machine à farcir les saucisses. Corps en acier inox - 2 vitesses - livré avec 4 entonnoirs (10-20-30-35 mm).

DE Wurstfüllmaschine. Gehäuse aus Edelstahl - 2 Geschwindigkeiten - 4 Trichter (10-20-30-35 mm) im Lieferumfang enthalten.

ES Máquina para embutir. Estructura de acero inoxidable. 2 velocidades - en la dotación 4 embudos (10-20-30-35 mm).

RU Машина для заправки сосисок. Корпус из нержавеющей стали - 2 скорости - поставляется с 4 воронками (10-20-30-35 мм).

	ABX-SS7H	ABX-SL12H
	7 L	12 L
	820 x 340 x 340(h) mm	950 x 410 x 350(h) mm
		
	13 Kg	28 Kg
	14 Kg	31 Kg
	630 x 240 x 220(h) mm	750 x 310 x 290(h) mm
	0,033 m ³	0,06 m ³
		
	400 €	730 €



ABX-HF100
ABX-HF130



ABX-HF100

Pressamburger manuali



| Struttura in alluminio anodizzato, parti a contatto con la carne in acciaio inox.









EN Anodized aluminium casing, parts in contact with the meat in stainless steel.

FR Corps en aluminium anodisé, parties en contact avec la viande en acier inox.

DE Gehäuse aus eloxiertem Aluminium, mit dem Fleisch in Kontakt tretenden Teile aus Edelstahl.

ES Estructura de aluminio anodizado, las partes que están a contacto con la carne son de acero inoxidable.

RU Корпус из анодированного алюминия, детали, контактирующие с мясом, изготовлены из нержавеющей стали.

	ABX-HF100	ABX-HF130
		
	ø 100 mm	ø 130 mm
	320 x 250 x 300(h) mm	
		
	5,2 Kg	
	6,5 Kg	6,7 Kg
	275x220x295(h) mm	
	0,018 m ³	
		
	200 €	215 €
	Confezione cellophan da 1 Kg 1 Kg cellophane package Emballage cellophane de 1 Kg Zellophan-Verpackung 1 Kg Caja celofán de 1 Kg Упаковка целлофана 1 кг	
	38 €	42 €















ABX-T906



Bollitore elettrico



- IT** Bollitore elettrico in acciaio inox - spegnimento automatico al raggiungimento dell'ebollizione - due livelli di potenza - capacita contenitore 1,7 L - livello acqua visibile - base in plastica.
- EN** Stainless steel electric kettle - automatically switches off when boiling temperature is reached - two power levels - 1.7 L container - visible water level - plastic base.
- FR** Bouilloire électrique en acier inox. Arrêt automatique une fois la température d'ébullition atteinte - deux niveaux de puissance - capacité du récipient 1,7 L - niveau d'eau visible - base en plastique.
- DE** Elektrischer Wasserkocher aus Edelstahl - automatische Abschaltung beim Kochen - zwei Leistungsstufen - 1,7 L Behälterinhalt. - sichtbarer Wasserstand - Kunststoffsockel.
- ES** Hervidor eléctrico de acero inoxidable - cierre automático cuando el agua hierve - dos niveles de potencia - capacidad 1,7 litros - nivel de agua visible - base de plástico.
- RU** Электрочайник из нержавеющей стали - автоматически выключается при достижении температуры кипения - два уровня мощности - 1,7 литровый контейнер - видимый уровень воды - пластиковое основание.

	ABX-T906
	1,85 - 2,2 kW
 1 Ph	220-240V/1N/50-60Hz
	1.7 L
	150 x 220 x 230(h) mm
	
 NET Kg	1,3 Kg
 GROSS Kg	1,5 Kg
 mm	220 x 180 x 250(h) mm
 m ³	0,010 m ³
	
	67 €



ABX-Z3035



Coltello elettrico



- IT Coltello elettrico con corpo in abs e lama in acciaio inox.
- EN Electric knife with abs casing and stainless steel blade.
- FR Couteau électrique avec corps en ABS et lame en acier inox.
- DE Elektrisches Messer mit Kunststoffgehäuse und Klinge aus Edelstahl.
- ES Cuchillo eléctrico con cuerpo de abs y cuchilla de acero inoxidable.
- RU Электрический нож с корпусом пресса и лезвием из нержавеющей стали.

	ABX-Z3035
	0,18 kW
 1 Ph	220-240V/1N/50Hz
 RPM	3000 rpm
 mm	470 x 140 x 70(h) mm
	
 NET Kg	1 Kg
 GROSS Kg	1,5 Kg
 mm	250 x 80 x 150(h) mm
 m ³	0,003 m ³
	
	45 €













ABX-SV130



Cottura sous-vide



- IT** Macchina per la cottura sottovuoto a bassa temperatura (sous-vide). Struttura in acciaio inox AISI 304 - capacità di scaldare tra i 20 e i 30 L di acqua - sensore di temperatura - precisione di lavorazione +/- 0,1°C - temperatura regolabile da 5 a 90° - timer da 5 minuti a 99 ore.
- EN** Low temperature vacuum cooking machine (sous-vide). Stainless steel AISI 304 casing - heating capacity between 20 and 30 L of water - temperature probe - processing precision +/- 0.1°C - temperature adjustable from 5 to 90° - timer from 5 minutes to 99 hours.
- FR** Machine de cuisson sous vide à basse température. Corps en acier inox AISI 304 - capacité de chauffer entre 20 et 30 L d'eau - sonde de température - précision de traitement +/- 0,1°C - température réglable de 5 à 90° - minuterie de 5 minutes à 99 heures.
- DE** Niedertemperatur-Vakuum-Gargerät (sous-vide). Gehäuse aus Edelstahl AISI 304 - Heizvermögen zwischen 20 und 30 l Wasser - Temperaturfühler - Verarbeitungsgenauigkeit +/- 0,1°C - Temperatur einstellbar von 5 bis 90° - Zeitschaltuhr von 5 Minuten bis 99 Stunden.
- ES** Máquina de cocción al vacío a baja temperatura (sous-vide). Estructura de acero inoxidable AISI 304 - capacidad para calentar entre 20 y 30 L de agua - sensor de temperatura - precisión de procesamiento +/- 0,1°C - temperatura ajustable de 5 a 90° - temporizador de 5 minutos a 99 horas.
- RU** Машина для низкотемпературного вакуумного приготовления (sous-vide). конструкция из нержавеющей стали AISI 304 - возможность нагрева от 20 до 30 л воды - датчик температуры - точность обработки +/- 0,1°C - температура регулируется от 5 до 90° - таймер от 5 минут до 99 часов.

	ABX-SV130
	1,5 kW
 1 Ph	220-240V/1N/50Hz
	20 / 30 L
	71 x 146 x 340(h) mm
	
 NET Kg	1,3 Kg
 GROSS Kg	1,5 Kg
 mm	180 x 110 x 375(h) mm
 m ³	0,0075 m ³
	
	375 €

ABX-BH5
ABX-BH7



ABX-BH5



ABX-BH7

Impastatrice planetaria

IT Macchine per diversi tipi di impasto quali pizza, pane, biscotti, croissant, brioches, bignè, pan di spagna, pasta frolla, meringhe, puree, salse varie, panna montata. Struttura verniciata bianca - 1 vasca da 4,7 L per la BH5 e da 7 L per la BH7 - 3 utensili in dotazione, uncino, spatola e frusta tutti in acciaio inox - regolatore di velocità. Accessori: Vasca supplementare.

EN Machine for different types of dough such as pizza, bread, biscuits, croissants, brioches, cream puffs, sponge cake, shortcrust pastry, meringues, purees, mayonnaise, various sauces, whipped cream, etc. White coated casing - 1 4,7 lt bowl on BH5 and 7 lt bowl on BH7 - equipped with 3 tools, hook, beater and whisk in stainless steel - speed regulator. Accessories: Additional bowl.

FR Machine pour différents types de pâte tels que pizza, pain, biscuits, croissants, brioches, pains à la crème, gâteau éponge, pâte brisée, meringues, purées, sauces, crème fouettée. Structure peinte en blanc - 1 cuve de 4,7 L pour le BH5 e de 7 L pour le BH7- 3 outils fournis, crochet, spatule et fouet tous en inox - régulateur de vitesse. Accessoires: Cuve supplémentaire.

DE Maschine für verschiedene Teigarten wie Pizza, Brot, Kekse, Croissants, Hörnchen, Beignets, Biskuitkuchen, Mürbeteig, Meringues, Pürees, verschiedene Soßen, Schlagsahne. Weiß lackiertes Gehäuse - 5-L Schüssel für BH5 und 7-L Schüssel für BH7- 3 Werkzeuge im Lieferumfang: Haken, Spachtel und Schneebesen alle aus Edelstahl - Geschwindigkeitsregler. Zubehör: Zusätzlichen Schüssel.

ES Máquina para varios tipos de masas, como pizza, pan, galletas, croissants, brioches, petisúes, bizcocho, merengues, pureas, varias salsas, nata montada. Estructura pintada de blanco - 1 cuba de 5 L por BH5 y de 7 l por BH7- 3 utensilios incluidos, gancho, espátula y batidor todos de acero inoxidable - regulador de velocidad. Accesorios: Cuba adicional.

RU Машина для приготовления различных видов теста, например, для пиццы, хлеба, печенья, круассанов, бисквита, песочного теста, беже, пюре, различных соусов, взбитых сливок. Белая окрашенная конструкция. 1 x 4,7л Чаша для BH5 и 1x7 л Чаша для BH7 - 3 принадлежностей из нержавеющей стали: тестовый крючок, лопатка и виск - регулятор скорости. Аксессуары: дополнительная дежа для теста.

	ABX-BH5	ABX-BH7
	0,3 kW	
	220-240V/1N/50-60 Hz	
	45-270 rpm	
	4,7 L	7 L
	325 x 230 x 400(h) mm	400 x 250 x 410(h) mm
	14 Kg	17 Kg
	16 Kg	19 Kg
	440 x 330 x 490(h) mm	490 x 320 x 520(h) mm
	0,0711 m³	0,0824 m³
	920 €	990 €

	ELACBH5VA	ELACBH7VA
	Vasca - Bowl - Cuve - Wanne - Depósito - Чаша объемом	
	5 L	7 L
	85 €	95 €

ABX-ET350G
ABX-E500A



ABX-E500A



ABX-ET350G

**Piastre
ad induzione**



- IT** Macchina con sistema di cottura ad induzione di calore dalla piastra al contenitore (di tipo metallico). Struttura in acciaio inox per il modello E500A - struttura in plastica per il modello ET350G - piastra in vetroceramica - touch control - timer digitale.
- EN** Machine with induction cooking system from the plate to the container (in metal). Stainless steel casing for the E500A model - plastic casing for the ET350G model - glass ceramic plate - touch
- FR** Machine avec système de cuisson à induction de la chaleur de la plaque au récipient (en métal). Corps en acier inox pour le modèle E500A - corps en plastique pour le modèle ET350G - plaque en vitrocéramique - commande tactile - minuterie numérique.
- DE** Maschine mit Induktionskochsystem von der Platte bis zum Behälter (aus Metall). Edelstahlgehäuse für das Modell E500A - Kunststoffgehäuse für das Modell ET350G - Glaskeramikplatte - Touch Control - Digitaler Timer.
- ES** Máquina con sistema de cocción por inducción de la placa al recipiente (en metal). Cuerpo de acero inoxidable para el modelo E500A - cuerpo de plástico para el modelo ET350G - placa vitrocerámica - control táctil - temporizador digital.
- RU** Машина с индукционной системой приготовления от плиты до контейнера (в металле). Корпус из нержавеющей стали для модели E500A - пластиковый корпус для модели ET350G - стеклокерамическая плита - сенсорное управление - цифровой таймер.

	ABX-ET350G	ABX-E500A
	1,8 kW + 1,70 kW	5 kW
	230V/1N/50Hz	-
	-	400V/3N/50Hz
	ø 255 mm	ø 218 mm
	610 x 370 x 56(h) mm	400 x 515 x 17(h) mm
		
	5 Kg	10 Kg
	6 Kg	11,5 Kg
	630 x 440 x 88(h) mm	600 x 472 x 223(h) mm
	0,0250 m³	0,0630 m³
		
	195 €	805 €

ABX-EMH450S

ABX-EMH600S

ABX-EMH800S



ABX-EMH450S





ABX-EMH600S

Salamandre



- IT** Macchina per scaldare, gratinare e tostare. Struttura in acciaio inox - griglia cromata - termostati - regolazione posizione griglia superiore.
- EN** Heating, grating and toasting machine. Stainless steel casing - chromed grill plate - thermostats - upper grill position adjustment.
- FR** Machine à chauffer, griller et toaster. Corps en acier inox - plaque de gril chromée - thermostats - réglage de la position de la grille
- DE** Heiz-, Grill- und Toastgerät. Gehäuse aus Edelstahl - verchromte Grillplatte - Thermostate - Einstellung der oberen Grillposition.
- ES** Máquina para calentar, gratinar y tostar. Carcasa de acero inoxidable - placa de parrilla cromada - termostatos - ajuste de la posición de la parrilla superior.
- RU** Аппарат для нагрева, решетки и поджаривания. Корпус из нержавеющей стали - хромированная пластина гриля - термостаты - регулировка положения верхнего гриля.

	ABX-EMH450S	ABX-EMH600S	ABX-EMH800S
	2,8 kW	4 kW	5,6 kW
	230V/1N/50-60Hz		-
	-	400V/3N/50Hz	
	0±140 mm		
	430 x 330 mm	590 x 330 mm	790 x 330 mm
	450 x 480 x 500(h) mm	600 x 480 x 520(h) mm	800 x 480 x 500(h) mm
			
	37 Kg	47 Kg	57 Kg
	39 Kg	49 Kg	59 Kg
	520 x 560 x 580(h) mm	670 x 560 x 580(h) mm	870 x 560 x 580(h) mm
	0,169 m³	0,218 m³	0,282 m³

			
	855 €	980 €	1.510 €



ABX-EG750

ABX-EG548
ABX-EG5482
ABX-EG750
ABX-EG750M



ABX-EG548

















ABX-EG750M

Fry Top
elettrici



- IT** Macchina elettrica per cottura a secco o ad olio. Struttura in acciaio inox - piano di cottura in acciaio liscio o misto (liscio e rigato) - termostati di regolazione temperatura 0÷300°C - cassetto raccolta residui di cottura.
- EN** Electric machine for dry or oil cooking. Stainless steel casing - cooking surface in smooth or mixed (smooth and ribbed) steel - temperature adjustment thermostats 0÷300°C - cooking residue collection drawer.
- FR** Machine électrique pour la cuisson à sec ou à l'huile. Corps en acier inox - surface de cuisson en acier lisse ou mixte (lisse et nervuré) - thermostats de réglage de la température 0÷300°C - tiroir de récupération des résidus de cuisson.
- DE** Gerät zum Trocken- oder Ölkochen. Struktur aus Edelstahl - Kochfläche aus glattem oder gemischtem Stahl (glatt und gerillt) - Thermostate zur Temperatureinstellung 0÷300°C - Schublade zur Sammlung von Kochrückständen.
- ES** Máquina eléctrica para cocinar en seco o en aceite. Estructura de acero inoxidable - superficie de cocción de acero liso o mixto (liso y acanalado) - termostatos de regulación de la temperatura 0÷300°C - cajón de recogida de residuos de cocción.
- RU** Электрическая машина для сухой или масляной варки. конструкция из нержавеющей стали - варочная поверхность из гладкой или смешанной (гладкой и ребристой) стали - термостаты регулировки температуры 0÷300°C - ящик для сбора остатков

	ABX-EG548	ABX-EG5482	ABX-EG750	ABX-EG750M
	3 kW		6 kW	
	230V/1N/50-60Hz		-	
	-		400V/3N/50Hz	
	0÷300°C			
	Liscio - Smooth Гладкий	Misto - Mixed комбинированная	Liscio - Smooth Гладкий	Misto - Mixed комбинированная
	552 x 366 mm		746 x 398 mm	
	560 x 470 x 250(h) mm		750 x 520 x 310(h) mm	
				
	25 Kg		38 Kg	
	27 Kg		41 Kg	
	615 x 535 x 300(h) mm		800 x 580 x 340(h) mm	
	0,0980 m³		0,158 m³	
				
	430 €		705 €	750 €



Scarica il catalogo completo



Cataloghi digitali, alberi felici:
scegli **Abintrax** che con **mydidactstore**,
abbraccia la sostenibilità!

Concessionario

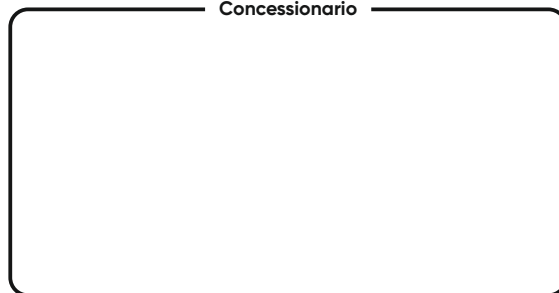

Abintrax s.r.l.

Via Marina del Mondo, 62 | 70043 Monopoli (Ba) Italy
tel. +39 080 2149700 | www.abintrax.com | info@abintrax.com

www.mydidactstore.it